

Introduction to Deep Learning

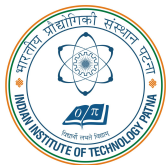

Arijit Mondal

Dept. of Computer Science & Engineering
Indian Institute of Technology Patna
arijit@iitp.ac.in

Neural Network

Human brain vs von Neumann computer

- Massive parallelism
- Distributed representation and computation
- Learning ability
- Generalization ability
- Adaptability
- Inherent contextual information processing
- Fault tolerance
- Low energy consumption

Computer vs Brain

	von Neumann	Neural system
Processor	Complex, high speed, one or a few	Simple, low speed, a large number
Memory	Separate from processor, Localized, Noncontent addressable	Integrated into processor, Distributed, Content addressable
Computing	Centralized, sequential, stored program	Distributed, parallel, self-learning
Reliability	Very vulnerable	Robust
Expertise	Numeric and symbolic manipulations	Perceptual problems
Operating environment	Well defined, well constrained	Poorly defined, unconstrained

Artificial Neuron: Applications

- Pattern classification

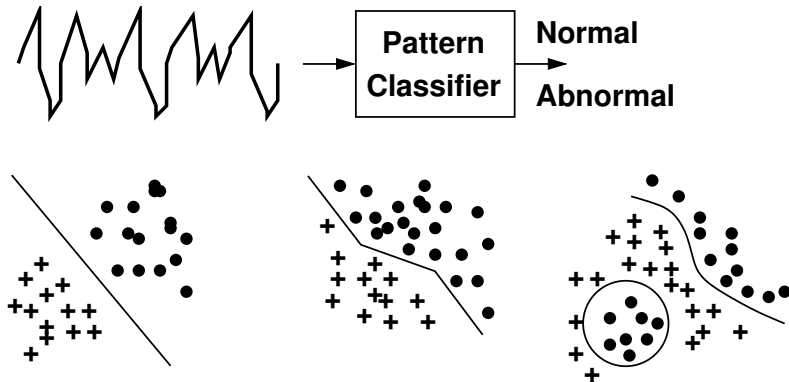

Artificial Neuron: Applications

- Clustering/categorization

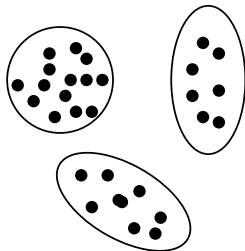

Artificial Neuron: Applications

- Prediction

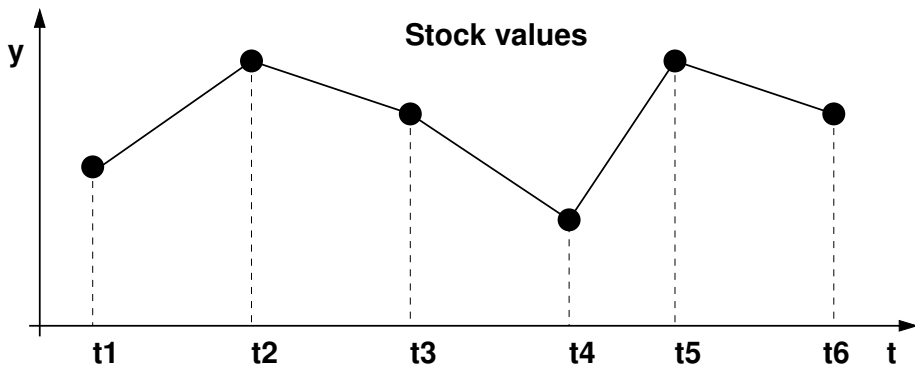

Artificial Neuron: Applications

- Retrieval

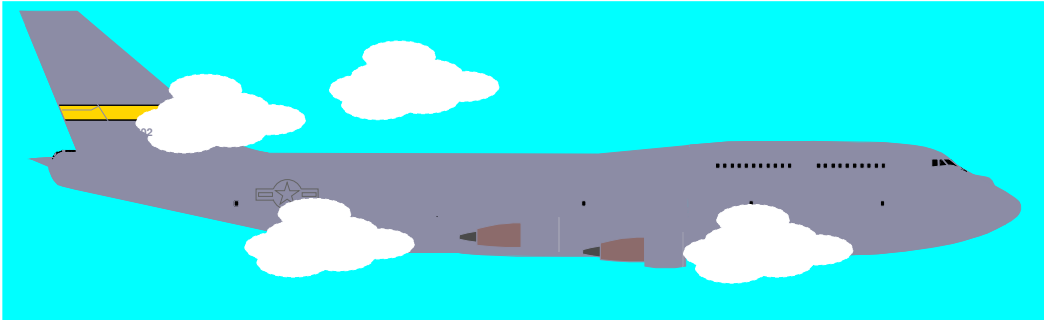

Artificial Neuron: Applications

- Optimization

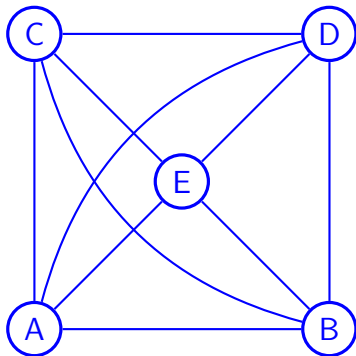

Artificial Neuron

- Control

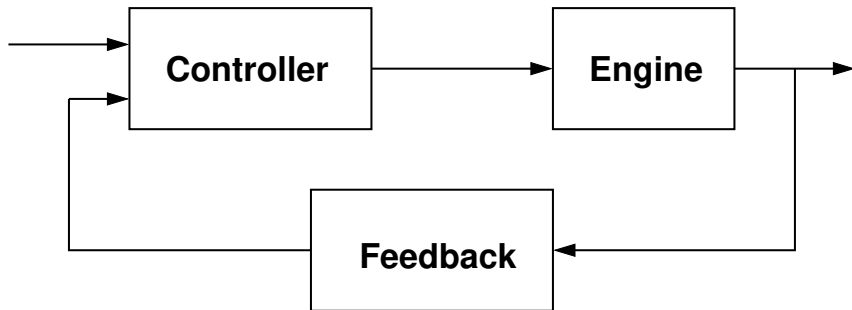

History

- Started in 1940s by McCulloch and Pitt
- Rosenblatt perceptron convergence theorem (1960)
- In 1980s ANN started gaining popularity
- Again became popular after 2006

Biological Neuron

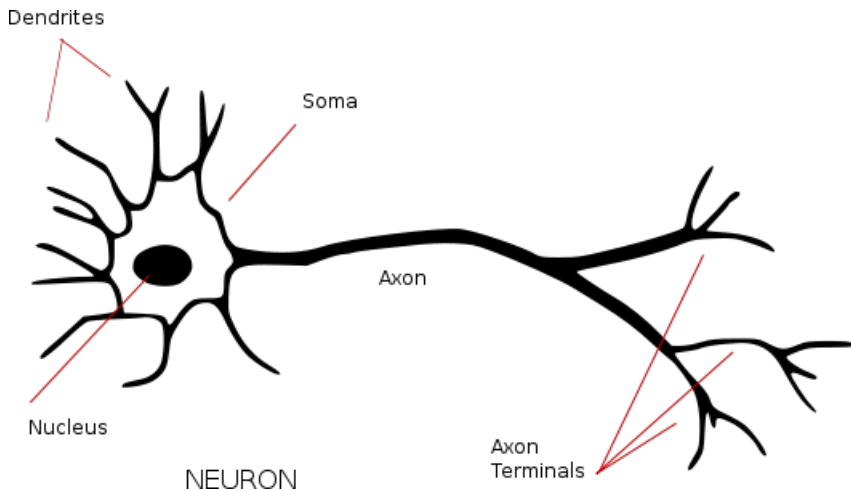

Image source: [Internet](#)

Cerebral cortex

- It is a flat sheet of neurons about 2-3 millimeter thick with surface area is 2200 cm^2
 - Twice the area of computer keyboard
- It contains around 10^{11} neurons
 - Number of stars in the Milky-way
- Each neuron is connected to 10^3 - 10^4 other neurons
- Total connections is around 10^{14} - 10^{15}
- Connectionist model

Human brain

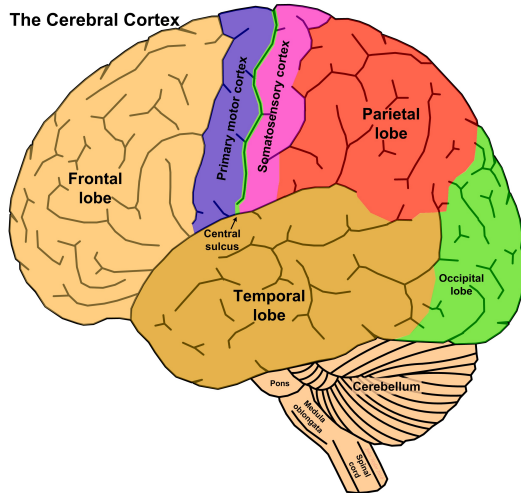
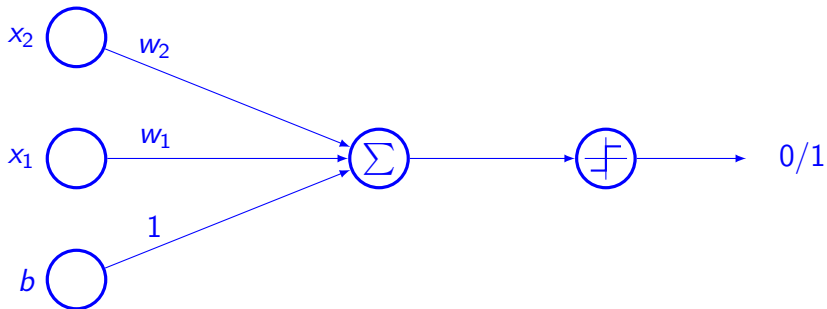

Image source: Internet

Neuron

- One of the primitive models



Artificial Neuron

- Neuron pre-activation function
 - $a(\mathbf{x}) = \sum_i w_i x_i + b = b + \mathbf{w}^T \mathbf{x}$
- Neuron output activation function
 - $h(\mathbf{x}) = g(a(\mathbf{x})) = g(\sum_i w_i x_i + b)$
- Notations
 - \mathbf{w} — Weight vector
 - b — Neuron bias
 - $g(\cdot)$ — Activation function

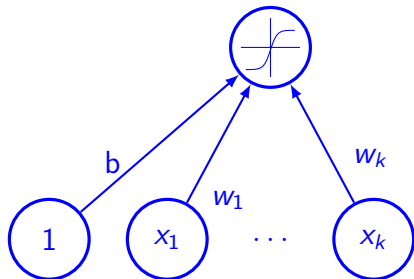

Physical interpretation

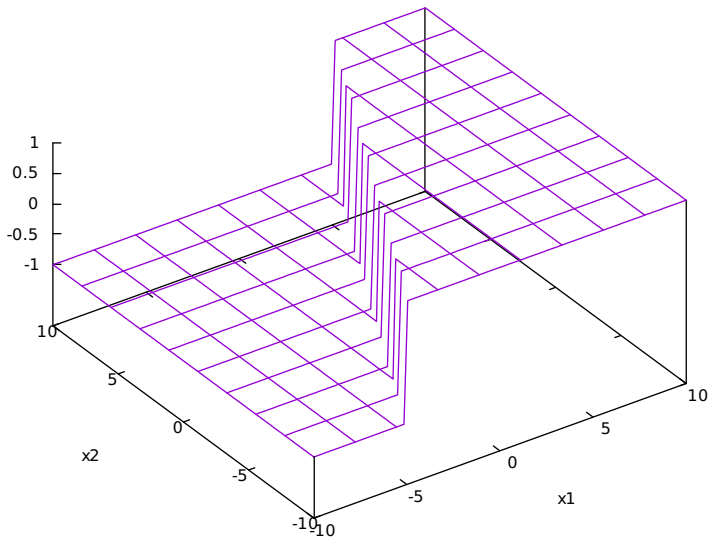

Classification using single neuron

- Single neuron can do binary classification
 - Also known as logistic regression classifier

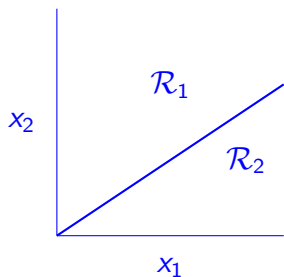
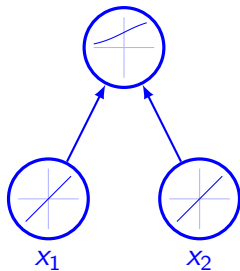

Artificial neuron

- Can solve linearly separable problems

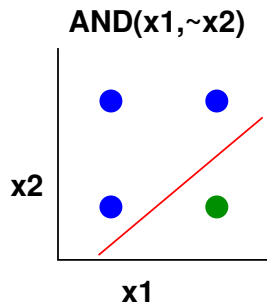
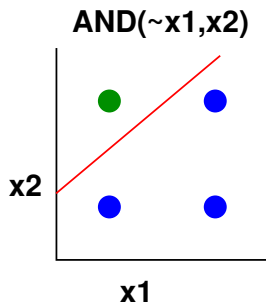
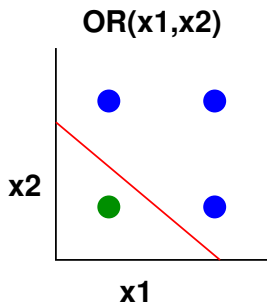

Artificial neuron: XOR problem

- There are issues for linear separation

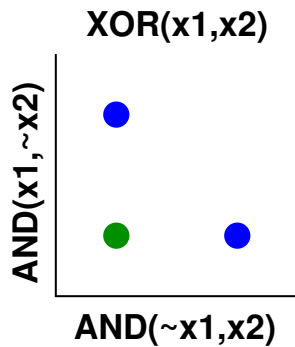
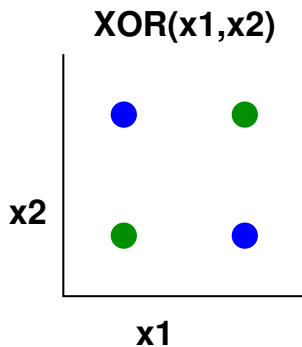

Activation function

- Linear activation function
 - Not very interesting
 - No change in values
 - Huge range

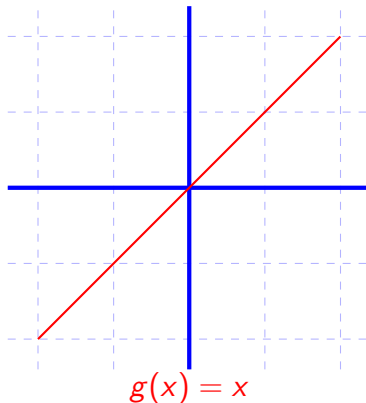

Activation function

- Sigmoid function
 - Values lie between 0 and 1
 - Strictly increasing function
 - Bounded

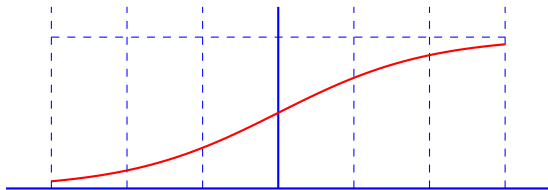

$$g(x) = \text{sigm}(x) = \frac{1}{1 + \exp(-x)}$$

Activation function

- Hyperbolic Tangent (Tanh) function
 - Can be positive or negative
 - Values lie between -1 and 1
 - Strictly increasing function
 - Bounded

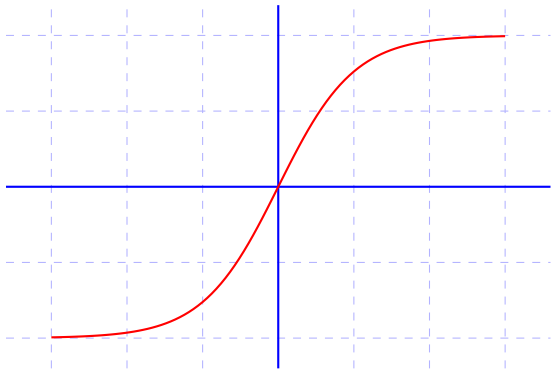

$$g(x) = \tanh(x) = \frac{\exp(x) - \exp(-x)}{\exp(x) + \exp(-x)}$$

Activation function

- Rectified linear activation function
 - Bounded below by 0
 - Strictly increasing function
 - Not upper bounded

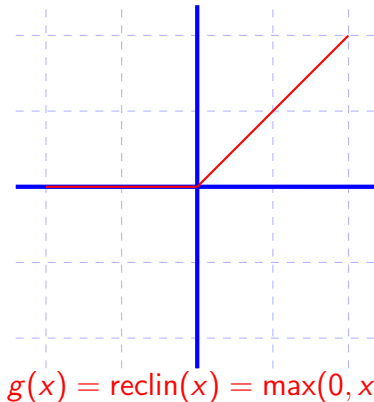

Single hidden layer neural network

- Hidden layer pre-activation

$$a(x) = b^1 + w^1 x$$

- Hidden layer activation

$$h(x) = g(a(x))$$

- Output layer activation

$$f(x) = o(b^{(2)} + w^{(2)T} h^1(x))$$

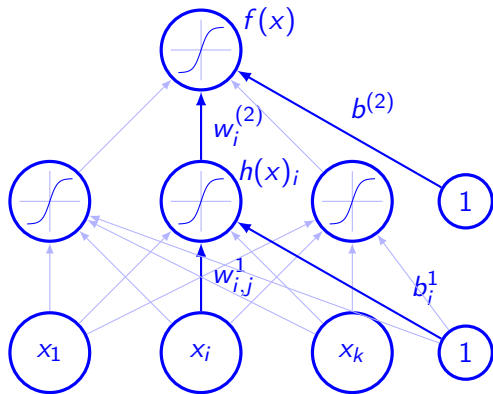

Multiclass classification

- Need multiple outputs that is one neuron for each class
- Need to determine probability of $p(y = c|x)$
- Softmax activation function is used at the output

$$o(\mathbf{a}) = \text{softmax}(\mathbf{a}) = \left[\frac{\exp(a_1)}{\sum_c \exp(a_c)} \quad \frac{\exp(a_2)}{\sum_c \exp(a_c)} \quad \cdots \quad \frac{\exp(a_c)}{\sum_c \exp(a_c)} \right]^T$$

- Strictly positive
- Sum to 1
- Class having the highest probability will be the predicted output

Multi layer neural network

- Pre-activation in layer $k > 0$ ($h^{(0)}(x) = x$)

$$a^{(k)}(x) = b^{(k)} + W^{(k)} h^{(k-1)} x$$

- Hidden layer activation

$$h^{(k)}(x) = g(a^{(k)}(x))$$

- Output layer activation

$$h^{(L+1)}(x) = o(a^{(L+1)}(x)) = f(x)$$

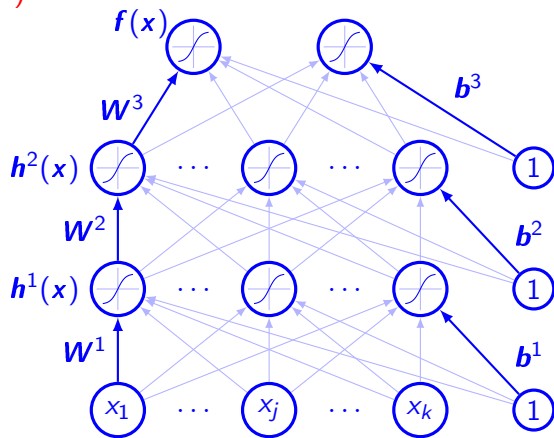

Capacity of neural network

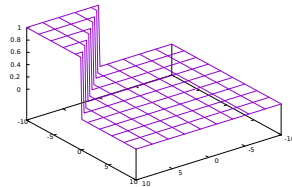
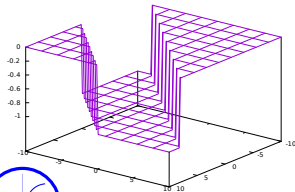
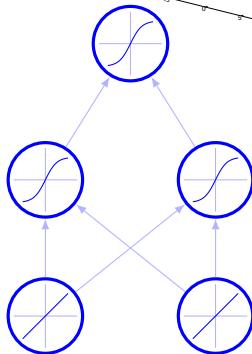
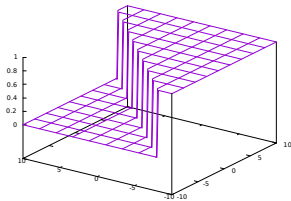

Capacity of neural network

- Universal approximation theorem (Hornik,1991)
 - A single hidden layer neural network with a linear output unit can approximate any continuous function arbitrarily well, given enough hidden units.
- The result is applicable for other hidden layer activation functions such as sigmoid, tanh, etc.
- This is a promising result, but it does not say that there is a learning algorithm to find the necessary parameter values!

Types of Neural Network

- Feed forward neural network
- Radial basis function network
- Recurrent neural network
- Boltzmann machine
- Long short term memory network
- and many more

Perceptron

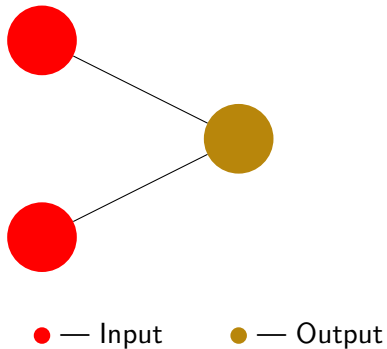

Feed Forward

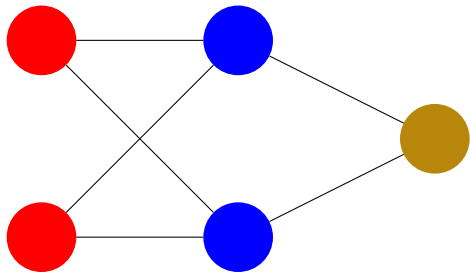

● — Input

● — Output

● — Hidden

Radial Basis Function

- Typically it will have 3 layers
- Distance from a center vector is computed

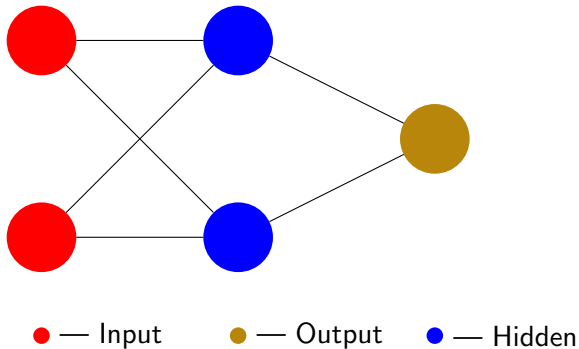

Deep Feed Forward

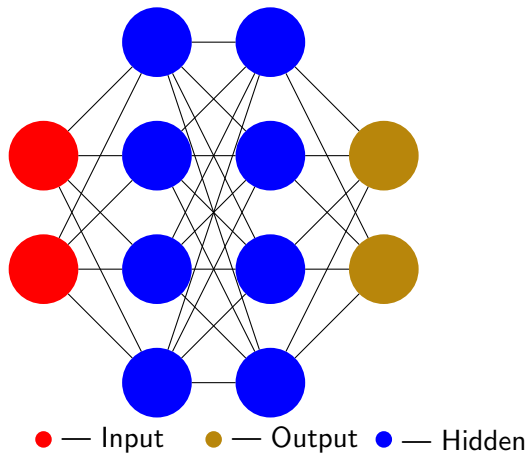

Recurrent Neural Network

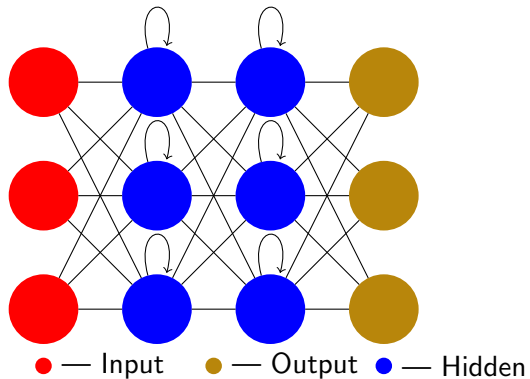

Long Short Term Memory

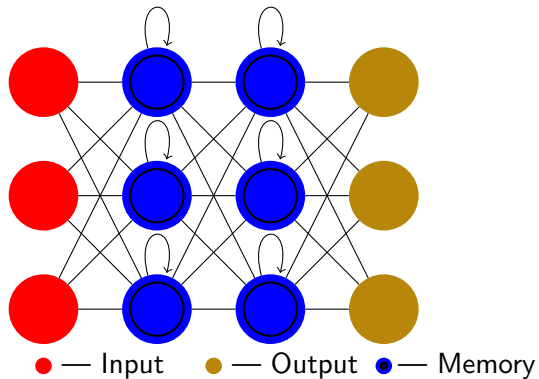

Auto Encoder

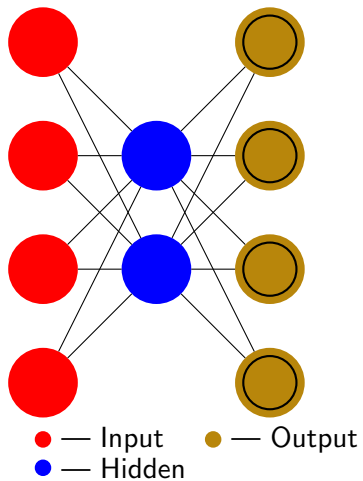

Markov chain

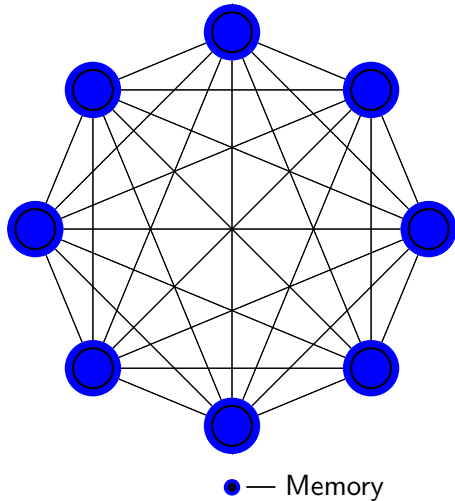

Boltzmann Machine

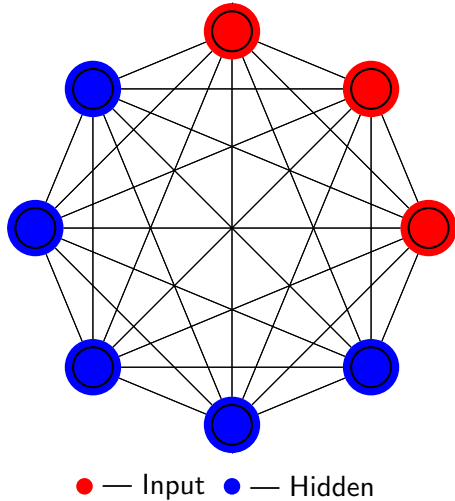

Learning the parameters

- The network must learn the connection weights from available training examples
- Learning can be
 - Supervised
 - Unsupervised
 - Hybrid
- Four basic types of learning rule
 - Error correction rule
 - Boltzmann learning
 - Hebbian
 - Competitive learning

Error correction rule

- Output is generated based on the weight values but this may vary from desired value
- The error information is used to update the weight value
- Perceptron learning algorithm
 - Initialize the weights and threshold to small random numbers
 - Present a pattern vector and evaluate the output of neuron
 - Update the weight according to $w_j(t+1) = w_j(t) + \eta(d - y)x_j$
- Back propagation algorithm

Boltzmann learning

- Usually symmetric recurrent network consisting of binary units
- A subset of neurons interact with environment
- Generally it has two modes
 - Clamped — Visible neurons are clamped to specific states
 - Free-running - Visible and hidden unit operate freely
- Stochastic learning rule derived from information theoretic and thermodynamic principles
- Learning rule is given by $\Delta w_{ij} = \eta(\bar{\rho}_{ij} - \rho_{ij})$

Hebbian rule

- One of the oldest learning rules
- If neuron on both sides of a synapse are activated synchronously and repeatedly, the synapse's strength is selectively increased
- Mathematically, it can be described as $w_{ij}(t + 1) = w_{ij}(t) + \eta y_j(t)x_i(t)$

Competitive learning rule

- Output units compete among themselves for activation
- Only one output is active at time
- Also known as winner-take-all
- Mathematically, it can be represented as $w_{i^*}x \geq w_i x$
- Competitive learning rule can be stated as

$$\Delta w_{ij} = \begin{cases} \eta(x_j^u - w_{i^*j}) & i = i^* \\ 0 & i \neq i^* \end{cases}$$

Summary

- Error correction rule — Single or multilayer perceptron
 - Pattern classification, function approximation, prediction, control
- Boltzmann — Recurrent
 - Pattern classification
- Hebbian — Multilayer feed forward
 - Pattern classification, data analysis
- Competitive
 - Within class categorization, data compression