

Introduction to Deep Learning



Arijit Mondal

Dept. of Computer Science & Engineering
Indian Institute of Technology Patna
arijit@iitp.ac.in

Course structure

- Introduction to big data problem & representation learning
- Overview of linear algebra and probability
- Basics of feature engineering
- Neural network
- Introduction to open-source tools
- Deep learning network
- Regularization
- Optimization
- Advanced topics
- Practical applications

Evaluation policy

- Mid-sem - 20%
- Project - 40%-60%
- End-sem - 20%-40%
- Paper presentation - 10% (Depending on class size)

Project & Presentation

- Group wise project
- A group can have 2-3 students (Depending on class size)
- Each group will be assigned papers for presentation in the class
- Presentation duration \sim 30 minutes

Books

- Deep Learning - Ian Goodfellow, Yoshua Bengio, Aaron Courville
- The Elements of Statistical Learning - Jerome H Friedman, Robert Tibshirani, Trevor Hastie
- Reinforcement Learning: An Introduction - Richard S Sutton, Andrew G Barto

Acknowledgement

- Deep Learning Book by Ian Goodfellow, Yoshua Bengio, Aaron Courville
- Presentation by Yann LeCun, Geoff Hinton, Yoshua Bengio
- Various websites for images
- Dr. Jacob Minz (Synopsys)
- IIT KGP Batch of 2001
 - Joydeep Acharya (Hitachi)
 - Sanjeev Kumar (Liv.AI)
 - Mithun Dasgupta (Microsoft)
 - Amit Kumar (Avnera)
 - Mrinmoy Ghosh (Facebook)
 - Animesh Datta (Qualcomm)
 - Bhaskar Saha (PARC)
 - Banit Agrawal (Facebook)

Introduction

Problem Solving Strategies for Big Data

- Need to solve problems efficiently and accurately when the input data is huge (\sim GB, TB order)
- Finding a deterministic algorithm is difficult
 - Need to find out features
 - Requires significant effort for model building
 - Need to have domain knowledge
- Statistical inference is found to be suitable
 - Feature selection is not crucial
 - Model will learn from past data

Applications: Computer vision

- 2d to 3d conversion
- Street view generation
- Image classifications
- Image segmentation



Image source: Internet

Applications: Activity Recognition

- Recognize activities like walking, running, cooking, etc. from still image or video data

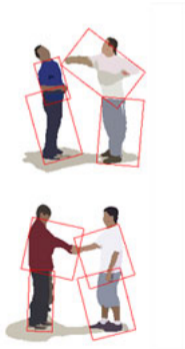

Applications: Image Captioning

- Automated caption generation for a given image







Describes without errors	Describes with minor errors	Somewhat related to the image	Unrelated to the image
			
<p>A person riding a motorcycle on a dirt road.</p>	<p>Two dogs play in the grass.</p>	<p>A skateboarder does a trick on a ramp.</p>	<p>A dog is jumping to catch a frisbee.</p>
			
<p>A group of young people playing a game of frisbee.</p>	<p>Two hockey players are fighting over the puck.</p>	<p>A little girl in a pink hat is blowing bubbles.</p>	<p>A refrigerator filled with lots of food and drinks.</p>
			
<p>A herd of elephants walking across a dry grass field.</p>	<p>A close up of a cat laying on a couch.</p>	<p>A red motorcycle parked on the side of the road.</p>	<p>A yellow school bus parked in a parking lot.</p>

Image source: Internet

Applications: Object Identification

- Identify objects in still image or in video stream

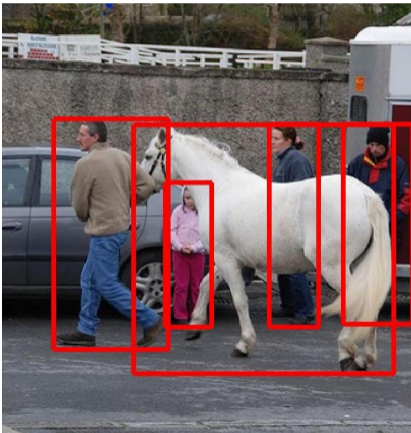

Image source: [Internet](#)

Applications: Automated Car

- Self driving car



Image source: Internet

Applications: Drones & Robots

- Managing movement of robot or drones



Image source: Internet

Applications: Natural Language Processing

- Recommender system
- Sentiment analysis
- Question answering
- Information extraction from website
- Automated email reply

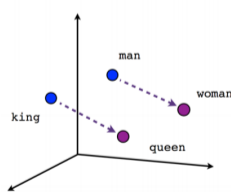

Male-Female

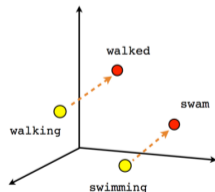

Verb tense

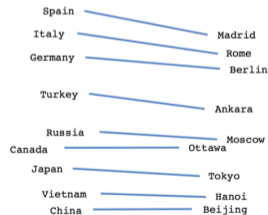

Country-Capital

Image source: Internet

Applications: Speech processing

- Conversion of speech into text
- Generation of particular voice for the given text

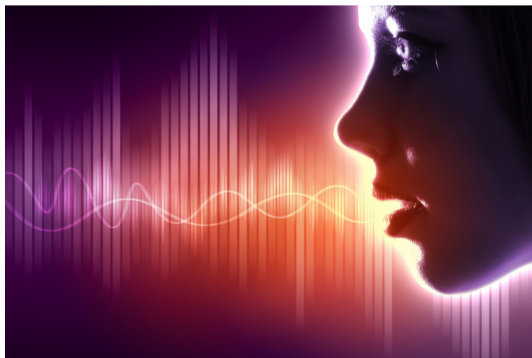

Image source: Internet

Other possible applications

- Write a story/text and generate a video/image of it
- Conversion of speech from one language to another language in real time
- Weather prediction
- Genomics
- Drug discovery
- Particle physics

Issue of Representation

- Representation of data in an efficient/structured manner is crucial for solving problems more effectively
 - Searching of a set of elements in a given list (sorted/unsorted)
 - Arithmetic operations on Arabic and Roman numerals
 - Primality test of n when n is represented as $11111\dots111$ (n -number of one)
- Structured representation can help in predicting future values

Learning representation/feature

- Traditional approaches
 - Pattern recognition
 - Input, output of the problem
- End to end learning
 - System automatically learns internal representation

AI-ML Tasks

- Heavily depends on features
- Requires good domain knowledge
- Feature extraction is not easy job
 - Identify a car
 - How to describe wheel
 - Shadow/brightness
 - Obscuring element

Representation Learning

- Learned representation often result in better performance compared to hand design
- Allows the system to rapidly adapt to new task
- Need to discover a good set of features
- Manual design of features is nearly impossible

Design of Features

- Goal is to separate out variation factors
- These factors are separate sources of influence
- It may exist as unobserved object or unobserved forces that affect observable quantity
 - Speech - Factors are age, sex, accent, etc
 - Image - Position, color, brightness, etc.

Deep Learning

- Try to address the problem of representation learning
- Representation are expressed in terms of other simpler representation
- Develop complex concept using simpler concept

Simple to Complex Features

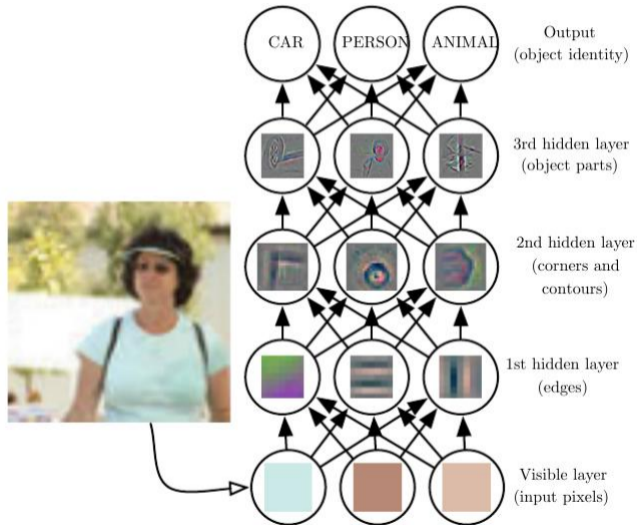

Image source: [Deep Learning Book](#)

Simple to Complex Features

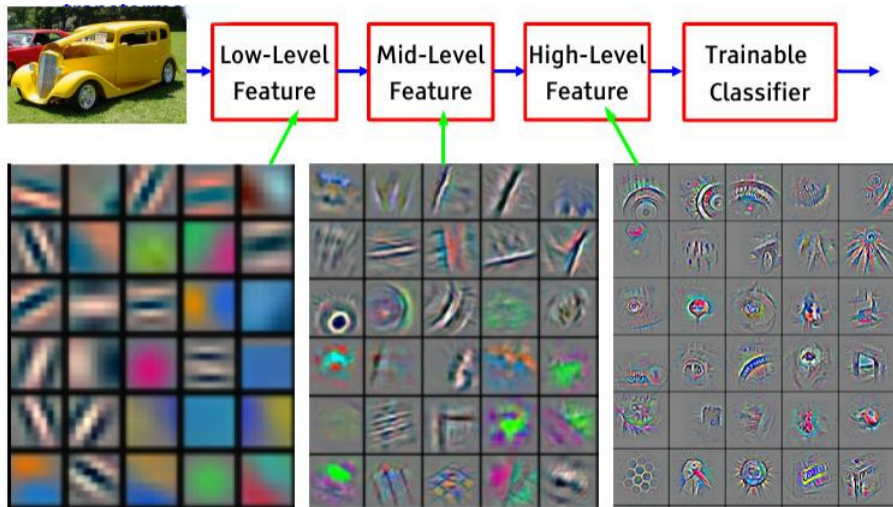
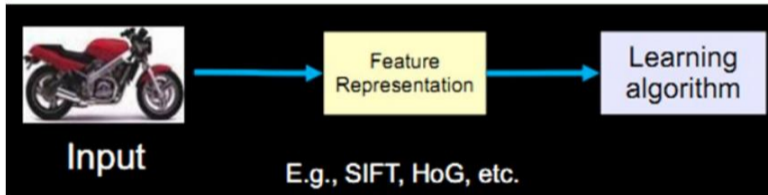
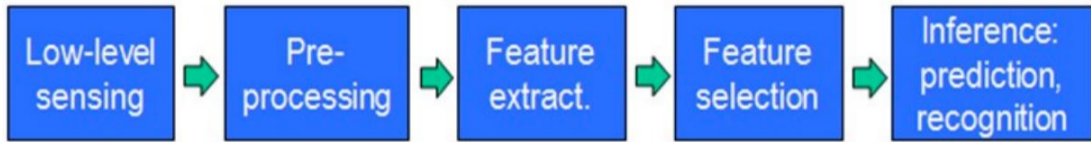

Image source: Deep Learning Tutorial by Yann LeCun Marc'Aurelio Ranzato, ICML, 2013

Conventional Machine Learning



Deep Learning Model

- Feed forward deep network or multilayer perceptron
- Mathematical functions that map input to output
- Composed of simpler functions
- Each layer provides a new representation
- Learning right representation

Representation learning

Rule based
system



Classic
machine
learning

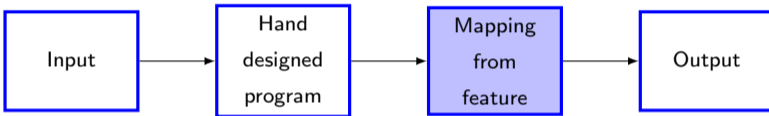

Deep
Learning

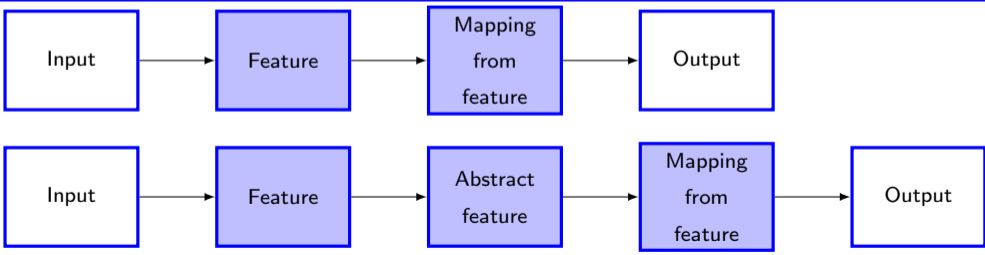

Depth of network

- Number of sequential instruction must be executed to evaluate the architecture
 - Length of the longest path
- Depth of the model

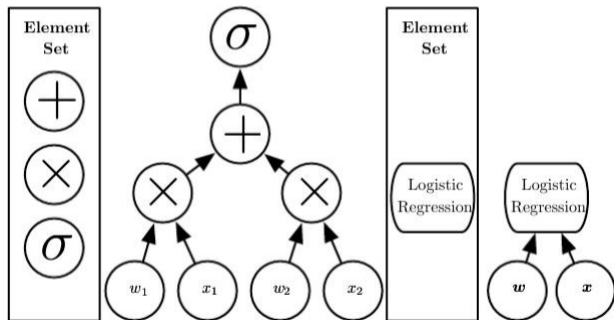

History

- Has many names and view point
 - Cybernetics (1940-1960)
 - Connectionism (1980-1990) (neural net)
 - Deep learning (2006+)
- More useful as the amount of data is increased
- Models have grown in size as increase in computing resources
- Solving complex problem with increasing accuracy

Learning Algorithm

- Early learning algorithm
 - How learning happen in brain?
 - Computational model of biological learning
- Neural perspective of DL
 - Brains provide a proof by example
 - Reverse engineer the computational principle behind the brain and duplicate its functionality

History of basic model

- The first learning machine: the Perceptron
 - Built at Cornell, 1960
- The perceptron was simple linear classifier on top of simple feature extractor
- Most of the practical applications of ML today use glorified linear classifiers or glorified template matching.
- Significant effort is required from the expert for identifying relevant features
- Typically it will solve $y = \text{sign} \left(\sum_{i=1}^N (w_i \times f_i(X) + b) \right)$

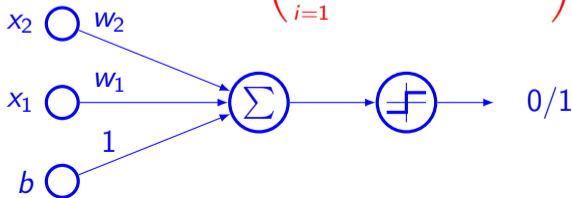

Broad Categories of Problem

- Regression

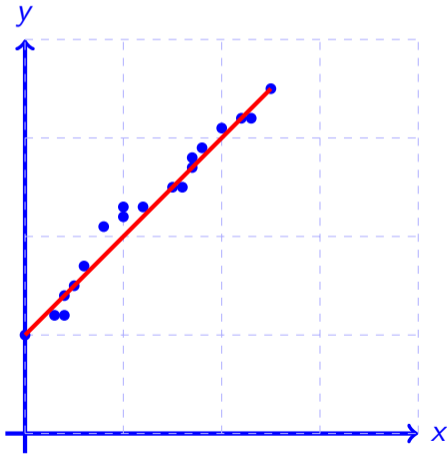

- Classification

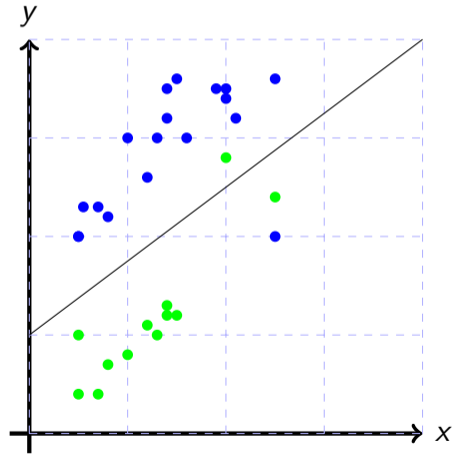

Regression

- Regression (linear)

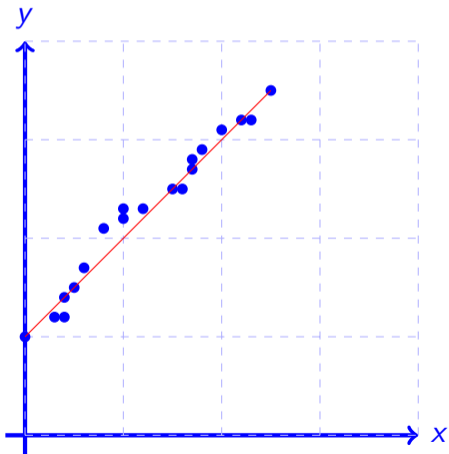

- Regression (Non-linear)

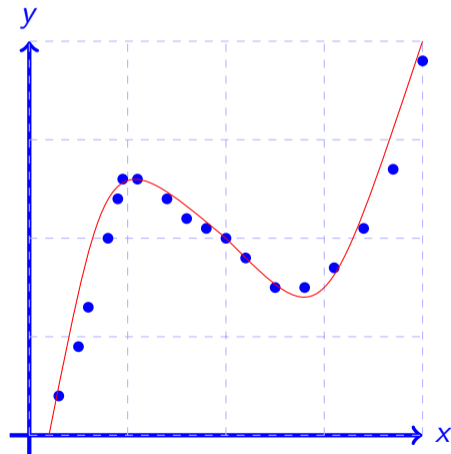

Classification

- Linear

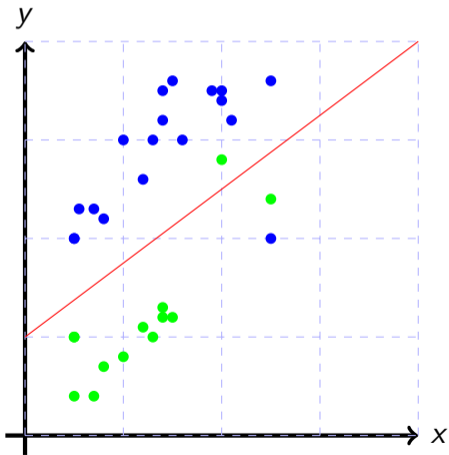

- Non-linear

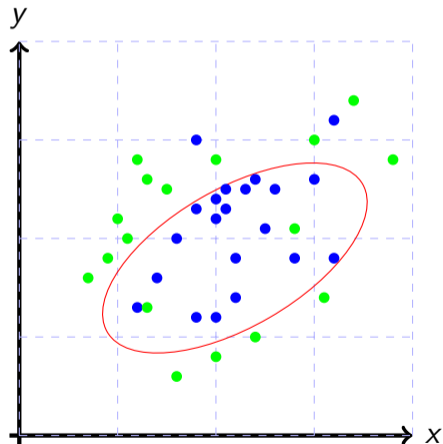

Artificial Neural Network

- A simple model

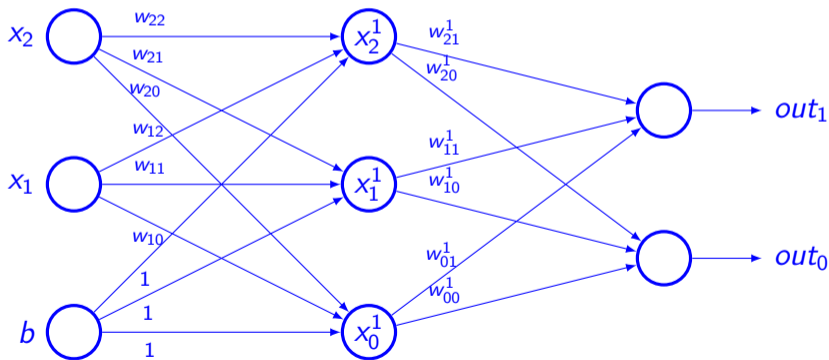

Example NN: AND gate

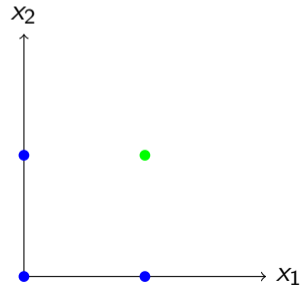
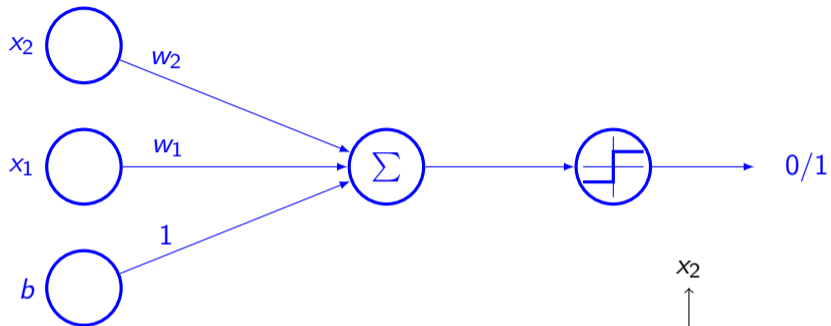

Example NN: AND gate

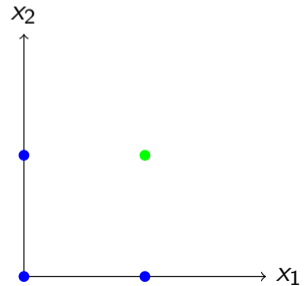
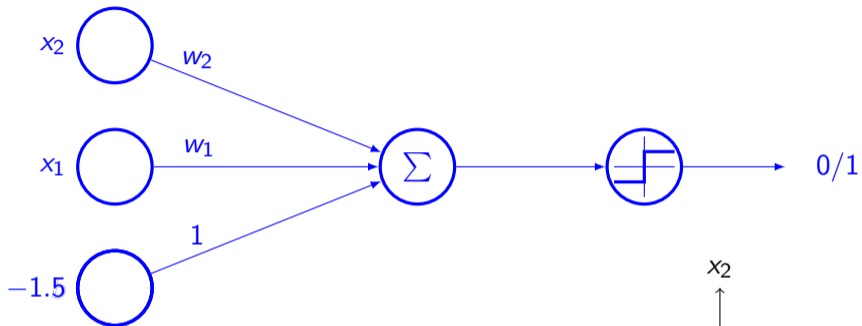

Example NN: AND gate

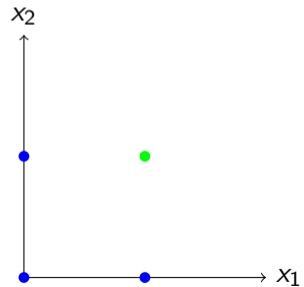
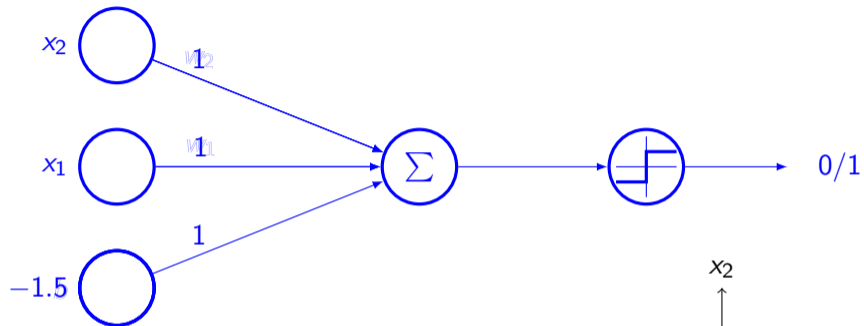

Example NN: AND gate

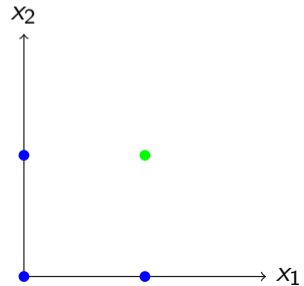
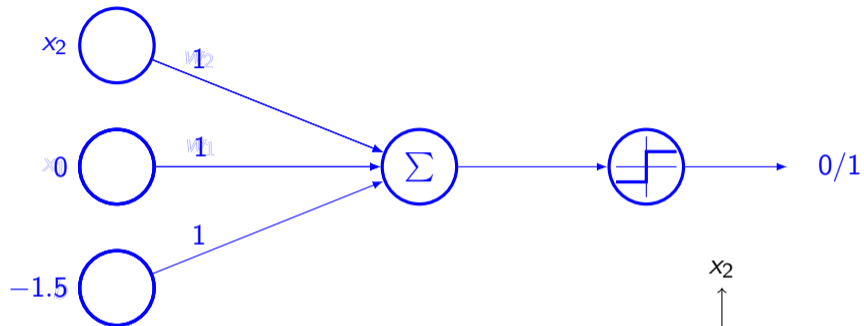

Example NN: AND gate

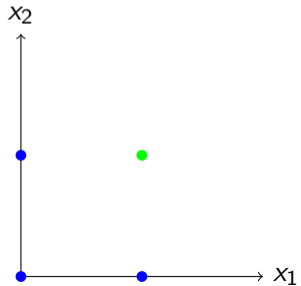
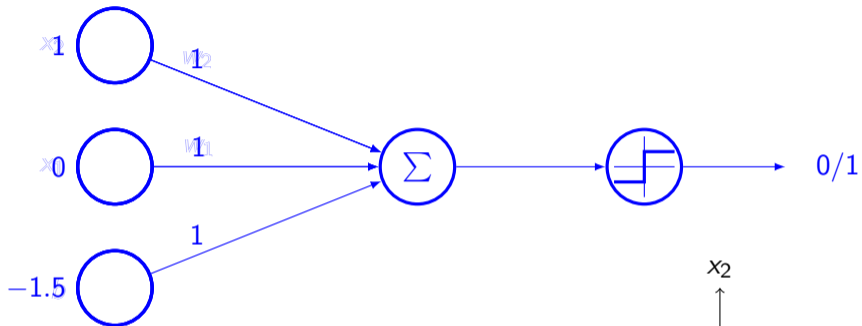

Example NN: AND gate

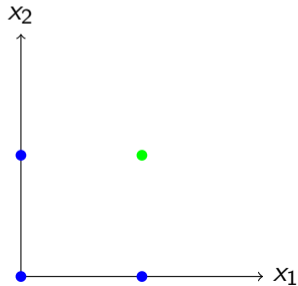
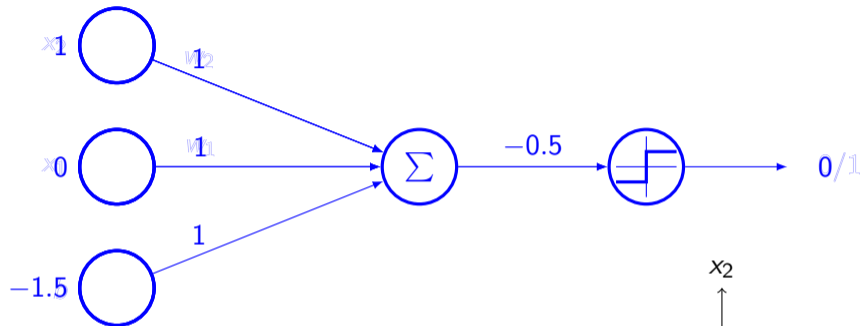

Example NN: AND gate

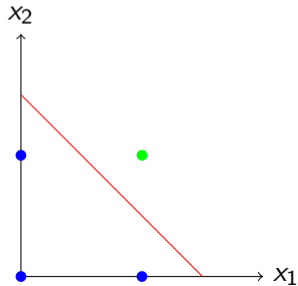
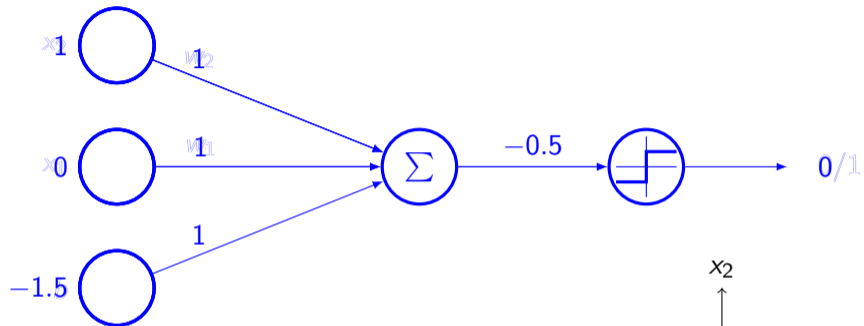

Example NN: XOR gate

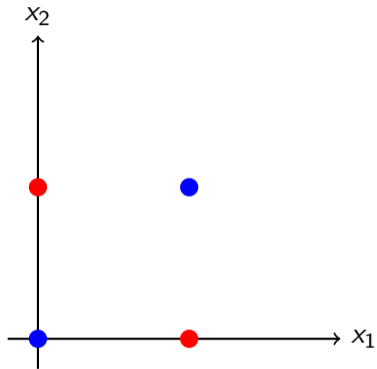

Example NN: XOR gate

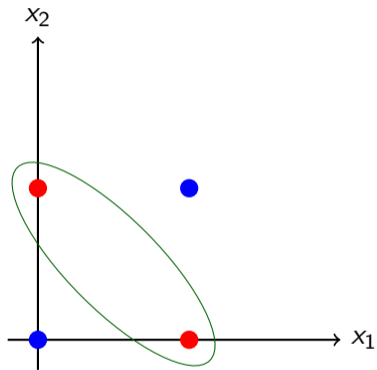

Example NN: XOR gate

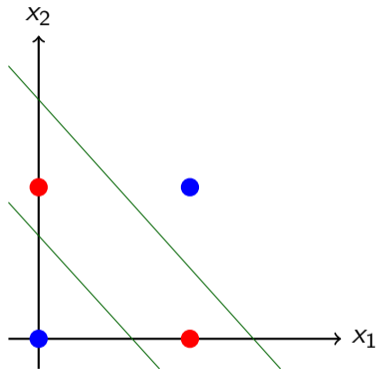
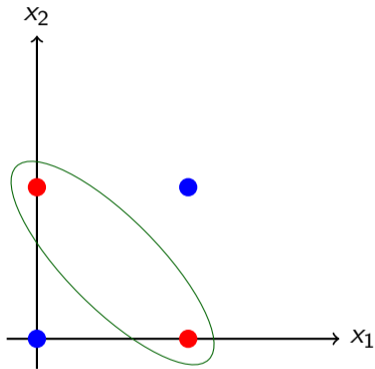

Distributed representation

- Each input should be represented by many features
- Each feature should be involved in the representation of many possible inputs
- Example: car, flower, birds — red, green, blue
 - 9 neurons
 - For each combination of color and object
- Distributed neurons
 - 3 Neurons for color
 - 3 Neurons for object
 - Total 6 neurons

Popularization of Neural Network

- Most of the theory of neural network was developed in the 1980s
- Started gaining popularity around 4-5 years ago
 - Geoffrey Hinton and Alex Krizhevsky winning the ImageNet competition where they beat the nearest competitor by a huge margin (2012)

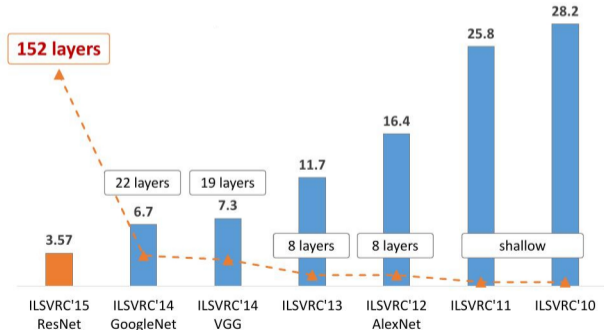

Image source: Deep Residual Learning by Kaiming He, et.al.

Popularity

- Increase data size
 - Computing resources are available
 - Accepting performance 5000 labeled example per category
 - 10 million for human performance
- Increasing model size
- Increasing accuracy, complexity, real world impact
- Used by many companies
 - Google, Microsoft, Facebook, IBM, Baidu, Apple, Adobe, Nvidia, NEC, etc.
- Availability of good commercial & open-source tools
 - Theano, Torch, DistBelief, Caffe, TensorFlow, Keras, etc.