

INDIAN INSTITUTE OF TECHNOLOGY PATNA

Name of Work:- Augmentation of the Electrical installation by SITC of Transformer , HT/LT Panels and allied works at Incubation Centre, IIT Patna.

January- 2024

TENDER DOCUMENT

INDIAN INSTITUTE OF TECHNOLOGY, PATNA
Bihta, Patna-801106 (Bihar)

INDEX

Name of work **Augmentation of the Electrical installation by SITC of Transformer , HT/LT Panels and allied works at Incubation Centre, IIT Patna.**

Sr. No.	Contents	Page No
1	Notice Inviting e-Tender	3-4
2	Instructions for online bid Submission	5-7
3	Information and Instructions for bidders	7-9
4	Eligibility Criteria	10
5	General terms and Conditions	11
6	Technical Specifications	12-18
7	Drawing	19-20
8	Make list	21
9	Schedules	22-23
10	Special Conditions	23-25
11	Annexures	26-31

INDIAN INSTITUTE OF TECHNOLOGY, PATNA

Bihta, Patna-801106 (Bihar)

1. Notice Inviting e-Tender

The Registrar, Indian Institute of Technology Patna, invites E- tenders item rate on prescribed tender documents under Two bid system (Technical and financial Bid) for the work of '**Augmentation of the Electrical installation by SITC of Transformer , HT/LT Panels and allied works at Incubation Centre, IIT Patna**' from the reputed, resourceful and experienced Manufacturers /Firms/Contractors who have executed similar nature works in any Central / State Government /PSU and who fulfill other eligibility criteria of Tender Document. Tender notice available on www.eprocure.gov.in/eprocure/app, www.iitp.ac.in.

a)	Bidding Document No.	IITP/IWD/IC/Elect./NIT-01/23-24
b)	Name of Work	Augmentation of the Electrical installation by SITC of Transformer, HT/LT Panels and allied works at Incubation Centre, IIT Patna'
c)	Estimated cost put to the Tender	Rs. 78,50,000/- (Rupees Seventy Eight lakh Fifty Thousand only).
d)	Time Period	3 Month
e)	Cost of Tender document.	NIL
f)	Earnest Money Deposit (EMD)	Earnest money Deposit (EMD) of Rs 1,57,000/- (Rupees One Lakh Fifty Seven Thousand only) to be deposited in the institute's account through SBI i-collect and the receipt of submission is to be uploaded along other technical bid documents. For details regarding submission of EMD, the webpage with following link may be visited: https://www.iitp.ac.in/images/pdf/snp/SBI%20I-Collect.pdf Alternatively, the bidders may provide DD, Fixed Deposit Receipt in favour of Registrar, IIT Patna.
g)	Date and Time for Issue	17.00 hrs. on 21.03.2024
h)	Bid Submission Start Date and Time	17.00 hrs. on 21.03.2024
i)	Bid Submission End Date and Time	17.00 hrs. on 04.04.2024

j)	Date and Time for Opening of Bids (Technical bid)	17.30 hrs. on 05.04.2024
k)	Date and Time for Opening of Bids (Financial bid)	To be intimated later
l)	Validity of Offer	120 Days from the date of opening of price bid
m)	Address for Communication	Head (IWD) (Institute Works Department) Indian Institute of Technology Patna, Kanpa Road, Bihta, Patna-801106 Ph:- +91-06115-233-8294 E-mail:- iwd_head@iitp.ac.in

The tender document can be downloaded from website. Corrigendum, if any would appear on the www.eprocure.gov.in/eprocure/app and IIT Patna website. IIT Patna reserves the right to reject any or all the tenders in part or full without assigning any reasons thereof.

2. INSTRUCTIONS FOR ONLINE BID SUBMISSION

The bidders are required to submit soft copies of their bids electronically on the CPP Portal, using valid Digital Signature Certificates. The instructions given below are meant to assist the bidders in registering on the CPP Portal, prepare their bids in accordance with the requirements and submitting their bids online on the CPP Portal. More information useful for submitting online bids on the CPP Portal may be obtained at: <https://eprocure.gov.in/eprocure/app>

REGISTRATION

- 1) Bidders are required to enroll on the e-Procurement module of the Central Public Procurement Portal (URL: <https://eprocure.gov.in/eprocure/app>) by clicking on the link “Online bidder Enrollment” on the CPP Portal which is free of charge.
- 2) As part of the enrolment process, the bidders will be required to choose a unique username and assign a password for their accounts.
- 3) Bidders are advised to register their valid email address and mobile numbers as part of the registration process. These would be used for any communication from the CPP Portal.
- 4) Upon enrolment, the bidders will be required to register their valid Digital Signature Certificate (Class III Certificates with signing key usage) issued by any Certifying Authority recognized by CCA India (e.g. Sify / nCode / eMudhra etc.), with their profile.
- 5) Only one valid DSC should be registered by a bidder. Please note that the bidders are responsible to ensure that they do not lend their DSC’s to others which may lead to misuse.
- 6) Bidder then logs in to the site through the secured log-in by entering their user ID / password and the password of the DSC / e-Token.

SEARCHING FOR TENDER DOCUMENTS

- 1) There are various search options built in the CPP Portal, to facilitate bidders to search active tenders by several parameters. These parameters could include Tender ID, Organization Name, Location, Date, Value, etc. There is also an option of advanced search for tenders, wherein the bidders may combine a number of search parameters such as Organization Name, Form of Contract, Location, Date, Other keywords etc. to search for a tender published on the CPP Portal.
- 2) Once the bidders have selected the tenders they are interested in, they may download the required documents / tender schedules. These tenders can be moved to the respective ‘My Tenders’ folder. This would enable the CPP Portal to intimate the bidders through SMS / email in case there is any corrigendum issued to the tender document.
- 3) The bidder should make a note of the unique Tender ID assigned to each tender, in case they want to obtain any clarification / help from the Helpdesk.

PREPARATION OF BIDS

- 1) Bidder should take into account any corrigendum published on the tender document before submitting their bids.
- 2) Please go through the tender advertisement and the tender document carefully to understand the documents required to be submitted as part of the bid. Please note the number of covers in which the bid documents have to be submitted, the number of documents - including the names

and content of each of the document that need to be submitted. Any deviations from these may lead to rejection of the bid.

3) Bidder, in advance, should get ready the bid documents to be submitted as indicated in the tender document / schedule and generally, they can be in PDF / XLS / RAR / DWF/JPG formats. Bid documents may be scanned with 100 dpi with black and white option which helps in reducing size of the scanned document.

4) To avoid the time and effort required in uploading the same set of standard documents which are required to be submitted as a part of every bid, a provision of uploading such standard documents (e.g. PAN card copy, annual reports, auditor certificates etc.) has been provided to the bidders. Bidders can use "My Space" or "Other Important Documents" area available to them to upload such documents. These documents may be directly submitted from the "My Space" area while submitting a bid, and need not be uploaded again and again. This will lead to a reduction in the time required for bid submission process.

Note: My Documents space is only a repository given to the Bidders to ease the uploading process. If Bidder has uploaded his Documents in My Documents space, this does not automatically ensure these Documents being part of Technical Bid.

SUBMISSION OF BIDS

1) Bidder should log into the site well in advance for bid submission so that they can upload the bid in time i.e. on or before the bid submission time. Bidder will be responsible for any delay due to other issues.

2) The bidder has to digitally sign and upload the required bid documents one by one as indicated in the tender document.

3) Bidder has to select the payment option as "offline" to pay the tender fee / EMD as applicable and enter details of the instrument.

4) Bidder should prepare the EMD as per the instructions specified in the tender document. The original should be posted/couriered/given in person to the concerned official, latest by the last date of bid submission or as specified in the tender documents. The details of the BG/any other accepted instrument, physically sent, should tally with the details available in the scanned copy and the data entered during bid submission time. Otherwise the uploaded bid will be rejected.

5) Bidders are requested to note that they should necessarily submit their financial bids in the format provided and no other format is acceptable. If the price bid has been given as a standard BoQ format with the tender document, then the same is to be downloaded and to be filled by all the bidders. Bidders are required to download the BoQ file, open it and complete the white coloured (unprotected) cells with their respective financial quotes and other details (such as name of the bidder). No other cells should be changed. Once the details have been completed, the bidder should save it and submit it online, without changing the filename. If the BoQ file is found to be modified by the bidder, the bid will be rejected.

6) The server time (which is displayed on the bidders' dashboard) will be considered as the standard time for referencing the deadlines for submission of the bids by the bidders, opening of bids etc. The bidders should follow this time during bid submission.

7) All the documents being submitted by the bidders would be encrypted using PKI encryption techniques to ensure the secrecy of the data. The data entered cannot be viewed by unauthorized persons until the time of bid opening. The confidentiality of the bids is maintained using the secured Socket Layer 128 bit encryption technology. Data storage encryption of sensitive fields is done. Any bid document that is uploaded to the server is subjected to symmetric encryption using a system generated symmetric key. Further this key is subjected to asymmetric encryption using buyers/bid opener's public keys. Overall, the uploaded tender documents become readable only after the tender opening by the authorized bid openers.

7) The uploaded tender documents become readable only after the tender opening by the authorized bid openers.

8) Upon the successful and timely submission of bids (i.e. after Clicking “Freeze Bid Submission” in the portal), the portal will give a successful bid submission message & a bid summary will be displayed with the bid no. and the date & time of submission of the bid with all other relevant details.

9) The bid summary has to be printed and kept as an acknowledgement of the submission of the bid. This acknowledgement may be used as an entry pass for any bid opening meetings.

ASSISTANCE TO BIDDERS

1) Any queries relating to the tender document and the terms and conditions contained therein should be addressed to the Tender Inviting Authority for a tender or the relevant contact person indicated in the tender.

2) Any queries relating to the process of online bid submission or queries relating to CPP Portal in general may be directed to the 24x7 CPP Portal Helpdesk.

3. Information and instructions for Bidder

INFORMATION AND INSTRUCTIONS FOR CONTRACTORS FOR e- TENDERING FORMING PART OF NIT AND TO BE POSTED ON WEBSITE

- a. Information and instructions for Contractors will form part of NIT and to be uploaded on <http://www.eprocure.gov.in/eprocure/app>, IITPATNA website.
- b. The bid document consisting of scope of works and the set of terms and conditions of the contract to be complied with and other necessary documents can be seen and downloaded from website <http://www.eprocure.gov.in/eprocure/app>. But the bid can only be submitted after uploading the mandatory scanned documents as per Eligibility Criteria.
- c. The Draft information and instructions to Contractors may be modified suitably by NIT approving authority as per requirement.
- d. The bidder must ensure to quote rate for each items separately in the specified column. If any column of rate against any item remains left blank by the bidder, it shall be treated that the bidder has quoted nil rate for that and the item will be executed by the bidder free of cost.
- e. IIT Patna shall not be responsible for non-receipt bid due to internet issues or any other reasons.
- f. The work is estimated to cost Rs.78,50,000/-.This estimate however, is given merely as a rough guide.
- g. Tender documents consisting of specifications, schedule of quantities of the various classes of work to be done and the set of terms & conditions of contract to be complied with by the contractor whose tender may be accepted and other necessary documents can be seen on website <http://www.eprocure.gov.in/eprocure/app>.

- h. The information and instructions for tenderers / bidders posted on the web-site shall form part of bid/tender documents.
- i. The bid can only be submitted after scanning and uploading the mandatory details within the period of tender submission as per critical data sheet.
- j. The Contractor, whose tender is accepted, will be required to furnish performance guarantee of 5 % (Five Percent) of the tendered amount within the specified period. The period of performance guarantee will be 30 months from award of work order. The performance guarantee will be return after 3 months over defect liability period. This guarantee shall be in the form Banker's cheque of any scheduled bank / Bank Guarantee of any scheduled bank. In case the contractor fails to deposit the said performance guarantee within the period, including the extended period if any, the Earnest Money deposited by the contractor shall be forfeited automatically without any notice to the contractor. IITP will deduct security deposit from each bill till the sum along with the sum already deposited as earnest money (if any), will amount to 5% of the total amount of the work. Security deposit will be refunded to agency after successful completion of Defect liability period.
- k. This Notice Inviting Tender shall form a part of the contract document. The successful tenderer/ contractor on acceptance of his tender by the Accepting Authority, shall sign the contract Agreement consisting of the notice inviting tender and all the documents. Also contractor shall submit Integrity pact as per format.
- l. There shall be defect liability period of 1 Years from date of successful completion/handover. During defect liability period, contractor has to rectify/replace defected items.
- m. Tenderers are advised to inspect and examine the site and its surroundings and satisfy themselves before submitting their tenders as to the nature of the ground and sub-soil (so far as is practicable), the form and nature of the site, the means of access to the site, the accommodation they may require and in general shall themselves obtain all necessary information as to risks, contingencies and other circumstances which may influence or affect their tender. A tenderer shall be deemed to have full knowledge of the site whether he inspects it or not and no extra charges consequent on any misunderstanding or otherwise shall be allowed. The tenderer shall be responsible for arranging and maintaining at his own cost all materials, tools & plants, water, electricity access, facilities for workers and all other services required for executing the work unless otherwise specifically provided for in the contract documents. Submission of a tender by a tenderer implies that he has read this notice and all other contract documents and has made himself aware of the scope and specifications of the work to be done and of conditions and rates at which stores, tools and plant, etc. will be issued to him by the Government and local conditions and other factors having a bearing on the execution of the work.
- n. Necessary NOC from statutory body shall be taken by contractor. No extra payment shall be consider for this purpose.
- o. This tender is being invited in compliance with Rule 144 (xi) of GFR Rules, 2017.
- p. The bidders are required to furnish a self-certificate regarding the items meeting local content requirement as per PP MII Policy.
- q. Any incidental/small work, which are necessary to complete the item in all respect will be done by contractor without any extra cost as per decision of E-in-Charge.
- r. Engineer-in charge may inspect power cable at manufacturer factory before dispatch.

- s. The competent authority does not bind itself to accept the lowest or any other tender and reserves the right to reject any or all the tenders received without the assignment of any reason. All tenders in which any of the prescribed condition is not fulfilled or any condition including that of conditional rebate is put forth by the tenderer shall be summarily rejected.
- t. Canvassing whether directly or indirectly, in connection with tenders is strictly prohibited and the tenders submitted by the contractors who resort to canvassing will be liable to rejection.
- u. Tender for the works shall remain open for acceptance for a period of 90 days from the date of opening of tenders. If any tenderer withdraws his tender before the said period or issue of letter of acceptance, whichever is earlier, or makes any modifications in the terms and conditions of the tender which are not acceptable to the Institute, then the Institute shall, without prejudice to any other right or remedy, shall not be allowed to participate in the re-tendering process of work.
- v. In case the contractor fails to commence the work specified in the tender documents on 7th day or such time as may be mentioned in the letter of award or from the date of handing over the site wherever is later, the Institute shall, without prejudice to any other right or remedy, be at liberty to forfeit whole of the earnest money absolutely.
- w. The bidders may contact to AEE(Electrical), IWD, IIT Patna (Ph:- 0612-3028710) for any clarification during the office hrs.
- x. The Bidder(s) may note that ONLINE BIDS will only be accepted. All the requisite supporting documents mentioned in the bid document should and must be uploaded. The Bids sent through FAX, E-mail, by hand and/or by post shall not be accepted/ processed in any case.
- y. In case, holiday is declared by the Government on the day of opening the bids, the bids will be opened on the next working day at the same time. The IITP reserves the right to accept or reject any or all the tenders.
- z. Conditional tenders will be summarily rejected.

4. Eligibility Criteria:

Contractors/ vendors who fulfill the following requirements shall be eligible to apply.

Eligibility criteria:- Applications from consortium/ joint ventures shall not be accepted. Experience of only the bidding entity shall be considered.

The applicant has successfully completed following works during last seven years with Central/State Government Organization/ Central Autonomous Body/ Public Sector Undertaking.

(i) One *similar completed work costing not less than the amount equal to 80% of the estimated cost.

OR

(ii) Two *similar completed works costing not less than the amount equal to 60% of the estimated cost.

OR

(iii) Three *similar completed works costing not less than the amount equal to 40% of the estimated cost.

- "Similar work" shall mean 'SITC of Substation Equipment, 200kVA or above capacity Transformer and HT/LT Panels' during last seven years ending on last date of the month previous to the one in which applications are invited.
- Agency should have a valid Electrical License of appropriate category.
- A Completion certificate from Client along with copy of Award letter/ Work Orders/BOQ must be submitted by the bidder.

5. List of Documents to be uploaded for technical eligibility

- a) Scanned copy of receipt of EMD of Rs 1,57,000/-.
- b) Scanned copy of Experience certificates as defined in eligibility criteria.
- c) Scanned copy of GST No and Scanned copy of Pan Card.
- d) Scanned copy of Audited Annual Accounts for Financial Years 2020-21, 2021-22 & 2022-23. Average Annual Turnover for last three financial years i.e. 2020-21, 2021-22 & 2022-23 should not be less than estimated amount (Rs 78,50,000/-).
- e) Scanned copy of EPF & ESI Registration Certificate (If not applicable- than please submit Notarized undertaking that ESIC and/or EPF is not applicable to your firm).
- f) Bank Solvency certificate of minimum 50% of estimate cost (i.e. Rs 39,25,000/-) in favour of bidder firm issued by bidder bank to be submitted. It should not be older than 6 months from last date of bid submission.
- g) Valid Electrical Contractor License of bidder in appropriate category.
- h) Bidder should not be blacklisted by any government department during last 3 years. Notarized Undertaking to be submitted by bidder.
- i) Local content self-certificate as per PP MII Policy.
- j) Scanned copy of Annexure-1,3,4,5.

Note: - Technical Bid will be evaluated along with above mentioned documents/credential (i.e. from a to i)

**Registrar
IIT Patna**

6. General terms and Conditions

- 1) Engaged manpower should not be paid less than minimum wages and allowances notified by Govt. time to time. Wage payment details of engaged manpower should be furnished to IITP when asked. Agency must follow the all labour relevant act and regulation.
- 2) At any stage, if it is opined by IIT Authority that the agency is not performing satisfactorily as per system requirement, IIT reverses right to terminate the contract as deemed fit after giving 7 days notice. In such a situation, IIT may engage another agency on contractor's Risk and Cost. The security deposit of the agency will be forfeited by the Institute, if agency leaves the contract before contract ending period or non-completion of the full contract.
- 3) All safety measures will be the responsibility of agency at their own cost. The agency will be solely held responsible for any accident occurring due to non-compliances of safety measures.
- 4) Necessary Insurance policy(CAR & Workman compensation) shall be taken by contractor as per rule.
- 5) Copies of drawings and SLD pertaining to the work can be seen by the bidders at office of the , IIT Patna if available.
- 6) IITP reserves the right to reject any tender/bid wholly or partly without assigning any reason.
- 7) IITP shall have the right to verify the particulars furnished by the bidder independently.
- 8) Additional conditions specifications, if any, forming the tender as issued at the time of invitation of tender and acceptance thereof together with any correspondence leading thereto.
- 9) The bid submitted shall become invalid if:
 - (i) The bidder is found ineligible.
 - (ii) The bidder have not submitted taxation authorities registration certificate and labour law registration certificate such as service tax/ GST/CST /ESIC/EPF etc. as stipulated in the bid Document. (If applicable)
- 10) The acceptance of a tender will rest with the Competent Authority IIT Patna who does not bind him to accept the lowest tender and reserves to himself the, authority to reject any or all the tenders received without the assignment of any reason. All tenders in which any of the prescribed conditions are not fulfilled or are incomplete in all respects are liable to be rejected.
- 11) The rates quoted against work should be for the complete finished item of Work and include all labour, material, taxes, overhead, duties, cess, insurance etc. Sales tax or any other tax in respect of this Contract shall be payable by the contractor and IITP will not entertain any claim whatsoever in this respect. So the rates are to be quoted are inclusive of all taxes.

7. Scope of Work:-

1. Supply, Installation, Testing & Commissioning of Transformer, HT & LT Panels and other allied items as per BOQ.
2. Installation of all Items on suitable foundation as per loading capacity and OEM Foundation drawing.
3. Submission of Technical data sheet, drawings and details of all items for approval from Engineer-in charge after award of work before placing manufacturing/supply order by agency.
4. Factory inspection of all items as decided by Engineer-in charge before dispatch to site from manufacturer works.
5. Testing of all items as per specification, codes as decided by Engineer-in charge before commissioning.
6. Commissioning of all items.
7. Submission of Final drawings, test reports, manuals, keys etc. after successful commissioning.

8. ELECTRICAL TECHNICAL SPECIFICATIONS

1. The work shall be carried out as per national code or C. P. W. D specifications for works with correction slips issued up-to date unless otherwise specified in the schedule of quantities for the works.
2. The following Indian Standard Specifications and Codes of Practice will apply to the equipment and the work covered by the scope of this contract. In addition the relevant clauses of the Indian Electricity Act 1910 and Indian Electricity Rules 1956 as amended upto date shall also apply. Wherever appropriate Indian Standards are not available, relevant British and/or IEC Standards shall be applicable.

BIS certified equipment shall be used as a part of the Contract in line with Government regulations. Necessary test certificates in support of the certification shall be submitted prior to supply of the equipment.

It is to be noted that updated and current Standards shall be applicable irrespective of those listed below.

Low voltage Switchgear and Control gear specifications	IS 13947: 1993
Part I – General	
Part 2 – Circuit Breakers	
Part 3 – Switch Fuse Units	
Part 4 – Contactors and Motor Starters	
Part 5 – Control Circuit Devices	
Electrical Relays for power system protection	IS 3231: 1986
Low voltage Switchgear and Control gear assemblies	IS 8623: 1993
Marking of Switchgear bus bars	IS 11353: 1985
Degree of Protection of Enclosures for low Voltage switchgear	IS 2147: 1962

CPWD General Specifications for Electrical Works to be followed:

- (Part I - Internal) - 2013. With latest amendment
- (Part II - External) - 2007. With latest amendment
- (Part IV - Substation) - 2013. With latest amendment
- (Part VII – DG Set) - 2013 With latest amendment

3. All the labour rules, regulations are to be followed while performing the work

4. STANDARD AND REGULATIONS

All equipments, switchgear, cables and other items of work shall conform to Indian/ **IEC** Standard specifications.

The installation shall conform in all respects to Indian Standards Code of Practice for Electrical wiring installation IS:732- 1989. It shall also be in conformity with the current Indian Electricity Rules and the Regulations and requirements of the Local Electric Supply Authority, Local laws/by laws in so far as these become applicable to the installation. Wherever these specifications call for a higher standard of materials and /or workmanship than those required by any of the above regulations, these specifications shall take precedence over the said regulations and standard. In general, the materials, equipment and workmanship shall conform to the following Indian Standards, unless otherwise called for.

- * XLPE insulated PVC sheathed armoured
Cables of 33kV grade as per IS 7098 Part-II with latest
amendments.
- * Marking and arrangements for Switchgear:
Bus bars, main connection and auxiliary wiring. IS 375 - 1963
- * Specifications for normal duty air break switches
and composite units for air break switches and
fuses for voltage not exceeding 1000 volts IS-13947-1993
(Part-I to V)
- * Specification for low voltage switchgear and control gear assemblies
IS 8623 -1993
(Part-I to III)
- * Specifications for enclosed distribution IS 2675 - 1983
- * Installation and maintenance of Switchgear IS 10118-1982
(Part-I to IV)
- * Code of practice for earthing IS 3043 -1987

A) SPECIFICATION FOR DISTRIBUTION TRANSFORMER

1.0 GENERAL:

This job covers design, manufacture, and assembly, shop testing, packing and delivery to site, supervision of erection, pre-commissioning tests and commissioning to ensure safe and trouble-free continuous operation of one (1) Nos. Indoor type, **oil-immersed 800 kVA 11/0.433 kV with OLTC**, Distribution Transformers to be installed on the transformer foundation.

1.1 Rating 800 kVA

1.2. Type of Cooling ONAN

1.3. Class of insulation Class A

1.4. No of phase and rated frequency 3, 50 Hz

1.5. Rated voltage (kV)

a) HV - 11

b) LV - 0.433

1.6. Connection

a) HV Delta

b) LV Star

1.7. VECTOR GROUP Dyn11

1.8. Winding

a) HV Copper

b) LV Copper

1.9. Insulation level (Impulse withstand) (kV peak)

HV 75

1.10. Insulation level (Power frequency withstand) (kV rms)

a) HV 28

b) LV 3

1.11. Tapping

a) Range +5% to -15% @ 2.5% Each

b) No of Steps 8

c) On HV side

d) Tap changer type- OLTC

1.12. Temperature rise of oil/winding over design ambient temperature of 50°C → 40/45(°C)

1.13. Hot spot temperature rise over a maximum yearly weighted temperature of 32°C → 98 °C

1.14. Short circuit Thermal withstand time (secs) - 2

1.15. % Impedance rated Frequency & current- 5.0 % with IS tolerance

1.16. Total losses @ 50% Load at rated voltage & frequency kW (MAX) - 2.287 (Approx.)

1.17. Total losses @ 100% Load at rated voltage & frequency kW (MAX) - 6.402 (Approx.)

1.18. Bushings HV

a) Reference standard - IS 2099 & IS 3347

b) Type of bushing Porcelain

c) Voltage Rating (kV) 17.5

d) Current Rating Amps Standard

1.19. Bushings LV & LVN

a) Reference Standard -

b) Type of bushing Epoxy

c) Voltage Rating (kV) 1

d) Current Rating Amps Standard

1.20. Fitting & Accessories as per specification AS PER - IS:2026 & CBIP

1.21. Reference standard - IS:2026

1.22. Termination

a) HV Cable Box

b) LV Cable Box

c) Orientation 180 Degree

1.23. Type of Transformer Tank -- Conventional

1.24 The turns ratio of the transformer shall be so selected that the LV side voltage at full load condition should be 433 V while the primary being at rated voltage on principal tap position.

1.25 The transformer shall be capable of operation continuously at its rated output without exceeding the temperature rise limits specified in the IS.

1.26 Transformer shall be capable of continuous operation at the rated output at any particular tap position under following power system conditions: -

- . Voltage variation of + 15% of the rated voltages of 11kV on primary side; 433 V on Secondary side.

- . Frequency variation of + 5% of rated frequency of 50 Hz

1.27 The transformer should be designed with particular attention to the suppression of harmonic voltage: especially 3rd, 5th, and 7th so that the detrimental effect therefore is avoided.

1.28 The Transformer should be absolutely free from noise and vibration even when operating at 10% higher voltage over the rated voltage.

1.29 Necessary first filling of oil shall be supplied for the transformer in non – returnable container for out-doors storage. 10% excess oil shall also be provided to take wastage into account.

2.0 CONSTRUCTIONAL FEATURES

2.1 The transformer tank should be welded in construction, fabricated from sheet steel of adequate thickness, ready to absorb stress due to short circuit.

2.2 The transformer shall be provided with bi-directional wheel, Jacking pads, lifting eye holes, pulling lugs, oil sampling taps on top as well as bottom, oil filter valves, thermometer pocket for top oil temperature, double diaphragm type explosion vent with equalizer pipe connection to conservator air space and silica gel breather.

2.3 The transformer bushing shall conform to the requirements of minimum clearance specified in I.S: 2026 with latest version. H.V. bushing shall be porcelain type with studs.

2.4 The core and coil assembly of the transformer shall have following features: -

- Interleaved grade non- aging, low loss, high permeability, grain oriented, cold rolled silicon steel lamination properly treated core material and electrolytic copper of suitable grade coils, both properly insulated and stacked to minimize impulse and power frequency voltage stress.

- Insulating spacers, barriers and bracings are designed for free oil circulation and minimum hot spot of the winding.

- Supports are to prevent vibration and short circuit stress.

- Fixed position with respect to the transformer movement and short circuit stress.

2.5 Marshalling Box: Sheet steel, weather proof with glass window. Complete with terminal block and wired up to the signaling devices provided on the transformer NCT, WTI, OTI, OLG, Buchholz Relay alarm & trip contacts, aux. Power supply, cubicle illumination lamp & door limit switch contacts terminated to the terminal block. Removable bottom gland plate for control cable entry.

1) FITTINGS AND ACCESSORIES

As per recommendation in the latest revisions IS but definitely including the following: -

- . Conservator tank connected to main tank by pipes through double float type Buchholz Relay with valves at both sides of the Relay and fitted with

- Dial type Magnetic oil level Gauge on one side and prismatic oil level gauge on the other side, both being visible from the ground level.

- . Buchholz Relay shall have separate alarm & trip contacts wired up to the terminal block of marshalling Box.

- . Winding Temperature Indicator with maximum, Reading Pointer and two separate contacts for alarm & trip duly wired up to the terminal block of Marshalling Box.

- . Oil Temperature Indicator with separate alarm & trip contacts wired up to the terminal block of Marshalling Box.

2.7 Capitalization of losses

The No Load Loss and Load Loss (Copper Loss) quoted by the Tendered shall be guaranteed under penalty.

Capitalization cost would be computed for evaluation purpose and later on penalty levied in case test figures differ with the guaranteed figures beyond IS tolerance.

2.8 Documents/Drawings to be submitted for approval from competent authority or Engineering in-charge.

- a) Technical particulars along with literature and write-up on the constructional features of each part, fittings and accessories.
- b) Details list of accessories & fitting.
- c) General Arrangement drawings of the transformer indicating the overall dimensions.
- d) Certified percentage impedance & loss figures.
- e) Type Test certificate including CPRI Test Report of an identical transformer.

Factory Inspection: Factory inspection and testing as decided by E-in-C.

Erection: The contractors are liable to perform all the arrangement for erecting the Transformer on MS channels including supply of iron channels of approx. size 150 x 75 x 75 mm as approved by the Engineer In-Charge or suitable sized and fixing them on cable trench with foundation bolts including supply of all hardware for complete execution of the job.

B) VACUUM CIRCUIT BREAKER Panel

Supply, erection testing and commissioning of CRAC single VCB Panel switchgear unit consisting of circuit breaker & busbar compartment with numerical protection relays, auxiliary relays, CT, PT, Indicator, MFM meter etc. VCB specification 11kV, 3 core, 50 Hz, 630 Amp, vacuum circuit breaker, dust and vermin proof totally enclosed in sheet steel housing fully interlocked, horizontal draw out, floor mounted truck type with motorized spring charging and manual spring charging mechanism with shunt trip and anti-pumping relay arrangement with ON /OFF /spring charge /Trip circuit healthy etc. indicators, earthing terminals, automatic safety shutters with locking facility complete with required no of auxiliary contact, Resin cast bar type CTs of suitable ratio 100/5/5 and accuracy class 1.0 and 5P 10 of burden 15VA and symmetrically fault current with standing capacity of 13.1 kA / Sec. Intelligent metering with MFM meter with RS 485 communication facilities with of 3 phases, 3 wires, 5 amps CL1 FM IPM 30 V0lts (L-L) is to be provided with each VCB units.

For Bus bar compartment shall have suitable capacity, non-hygroscopic and high di-electric strength SMC/FRP Bus bar supports with electrolytic Aluminium /Copper bus bar with suitable insulating sleeves. IDMT relays with 2 elements over load and 1 element earth fault with Master Trip relay.

The control ckt. is to be operated with 30V D.C from power pack D.C source **PT** should be with HT/LT fuses conforming to IS-3156 (with latest amendment)
P.T burden: 100VA/ Phase, Accuracy class: 1.0
Highest system voltage: 12 kV, INSL: 28 kV
Lightning Impulse Voltage: 75 kV, Connection: Y/Y IS: 3156
Test, trip push button, T-N-C breaker control switch, local, remote operation and electrical closing mechanism, indicating lamps, cable entry box including interconnection providing fire / heat resistance coating for metering, and breaker truck enclosure and painting as per IS: 2516 & IS: 34527.

VCB Statderds:-

IEC 62271-1: High-voltage switchgear and controlgear: common specifications –

IEC 62271-200: AC metal-enclosed switchgear and controlgear for rated voltages above 1 kV and up to and including 52 kV –

IEC 62271-100: High-voltage switchgear and controlgear - Alternating current circuit breakers -

IEC 62271-103: High-voltage switchgear and controlgear - Switches for rated voltages above 1 kV up to and including 52 kV –

IEC 62271-102: High-voltage switchgear and controlgear - Alternating current disconnectors and earthing switches –

IEC 60255: Measuring relays and protection equipment - Common requirements –

IEC 61869-2: Instrument transformers - Current transformers –

IEC 61869-3: Instrument transformers - Inductive voltage transformers

Erection: The contractors are liable to perform all the arrangement for erecting the VCB unit on MS channels including supply of MS Channels (of approx size 150 x 75 x 75 mm), foundation bolt,

assembling of various accessories including supply of all hardware for complete execution of the job.

C) SPECIFIC REQUIREMENT FOR POWER CONTROL CENTRE

1.0 GENERAL

Power control center panel or PCC shall comprise of panel Circuit Breaker assembly comprising of 2 Nos. 4pole 1600 amps Air Circuit Breaker with mechanical and electrical interlock facility) , 415Volts as incomer and outgoings consisting of the following features:-

- a) 630A MCCB, 4 pole,50kA with, microprocessor base releases (O/C.E/F, S/C) – 1no
 - b) 400 amps MCCB, 4 pole, with microprocessor based releases (O/C.E/F, S/C) -- 2no
 - c) 160 amps MCCB, 4 pole, with TM releases (O/C.E/F, S/C) -- 3no
 - d) TPN Aluminium Bus-Bar: 1600 amps with coloured insulated and sleeved Electrolytic AL/copper bus bars of 50 kA symmetrical fault current withstanding capacity.
- The ACB and MCCB should be mutually coupled with 415 volts TPN 1600 amps Bus Bars with suitable rated Al bars only.

CONSTRUCTION

- 1.1 Indoors, floor mounted, self- standing, compartmentalized cubicle type made of minimum 2mm thick CRCA steel sheet.
- 1.2 Front operated (having operating height between 450mm and 1800mm from operating floor) and rear access type.
- 1.3 Suitable for bottom and top entry cables depending on final lay out. Accordingly horizontal bus bar chamber will be either at bottom or at top.
- 1.4 Having detachable type gland plat of 4mm thickness for drilling and fixing of cable glands at site.
- 1.5 Each cubicle door casketed and having concealed type hinged front door knob.
- 1.6 Provided with a continuous earth bus bar of 50x6mm copper strip running throughout the entire length with two (2) earthing terminals at ends suitable for connecting specified PE conductors.

2.0 BUS-BARS

- 2.1 Bus-bar grade, high-conductive electrolytic copper / aluminium conductor having adequate size to carry the continuous current 1600 Amp breaking at the design ambient temperature and the max. Short circuit current specified.
- 2.2 Braced to withstand the short circuit force developed max short circuit specified for 1 second.
- 2.3 Provided with heat shrinkable type PVC insulating sleeves for bus bars and shrouds for bus bar joints, colour codes for three phases and neutral.
- 2.4 Bus bar supports of epoxy resin molded or FRP type insulator.

3.0 INCOMING FEEDERS AND OUTGOING FEEDERS

- 4.1 . 2 no. Incoming feeder shall be of Air Break, horizontal draw out (MDO) type 4 pole, 415V having continuous current rating of 1600 amps with Microprocessor based releases.
- a) 630A MCCB, 4 pole,50kA with, microprocessor base releases (O/C.E/F, S/C) – 1no
- b) 400 amps MCCB, 4 pole, with microprocessor based releases (O/C.E/F, S/C) -- 2no
- c) 160 amps MCCB, 4 pole, with TM releases -- 3no
- b) All ACB and MCCBs should be with microprocessor based releases having over current, short circuit and earth fault features and should have $I_{cs}=I_{cu}=I_{cw}=100%$ for ACBs and $I_{cs}=I_{cu} =100%$ for MCCBs

Special Feature: -

- 1.1 a) The circuit breakers shall be provided with manually operated spring charged stored energy closing mechanism, with features like solid state Release with Microprocessor based releases, shunt trip release, earth fault release, with fault indication etc and providing Intelligent panel meter (like QUASAR meter 3ph, 4 wire, 415 volt, LT meter with 5A CT, L& T make with RS 485 communication port) for each Air Circuit Breaker.
- b) The I/C unit should also have Digital type Voltmeter, Ammeter & C.T with selector switches apart from MFM.

- c) All C.Ts should be cast resin type.
- d) The I/C unit should also have Multifunctional Meter with RS485 port & Ammeter and volt meter with suitable rating C.T with selector switches.

1.2 ALL ACBs shall be provided with R, Y, B, ON, OFF, TRIP, SPRING CHARGE, TRIP CIRCUIT HEALTHY etc indicator and manual close and trip push buttons as required. All MCCB unit should have ON, OFF, TRIP indications, Rotary handles and spreader links. Interconnections with B/Bar should be with Suitable aluminium buses only.

1.3 The following indicating light (LEDs) on the front of the compartment shall be provided.

Breaker Open - GREEN

Breaker close - RED

Spring Charged - White

Trip circuit Healthy - Yellow

1.4 Mechanical safety inter lock shall be provided for: -

- a) The breaker cannot be plugged in or withdrawn from service position in closed condition.
- b) The breaker can only be operated either in TEST or SERVICE position and not permitted to operate in any other position in side the cubicle.

1.5 Each breaker shall have (for inter locking purpose in addition to auxiliary contacts)

a) Position switch with 4 NO. & 4 NC Contacts.

b) Auxiliary switch with 4NO & 4 NC contacts.

1.6 Breaker compartment shall be provided with a door, which can be closed with the breaker in any of the three positions namely 'SERVICE', 'TEST', and 'ISOLATED' position.

Erection: The contractors are liable to perform all the arrangement for erecting the PCC panel unit on MS channels including supply of iron channels of approx size 150 x 75 x 75 mm as approved by the Engineer and fixing them on cable trench with foundation bolts including supply of all hardware for complete execution of the job.

9. DRAWING

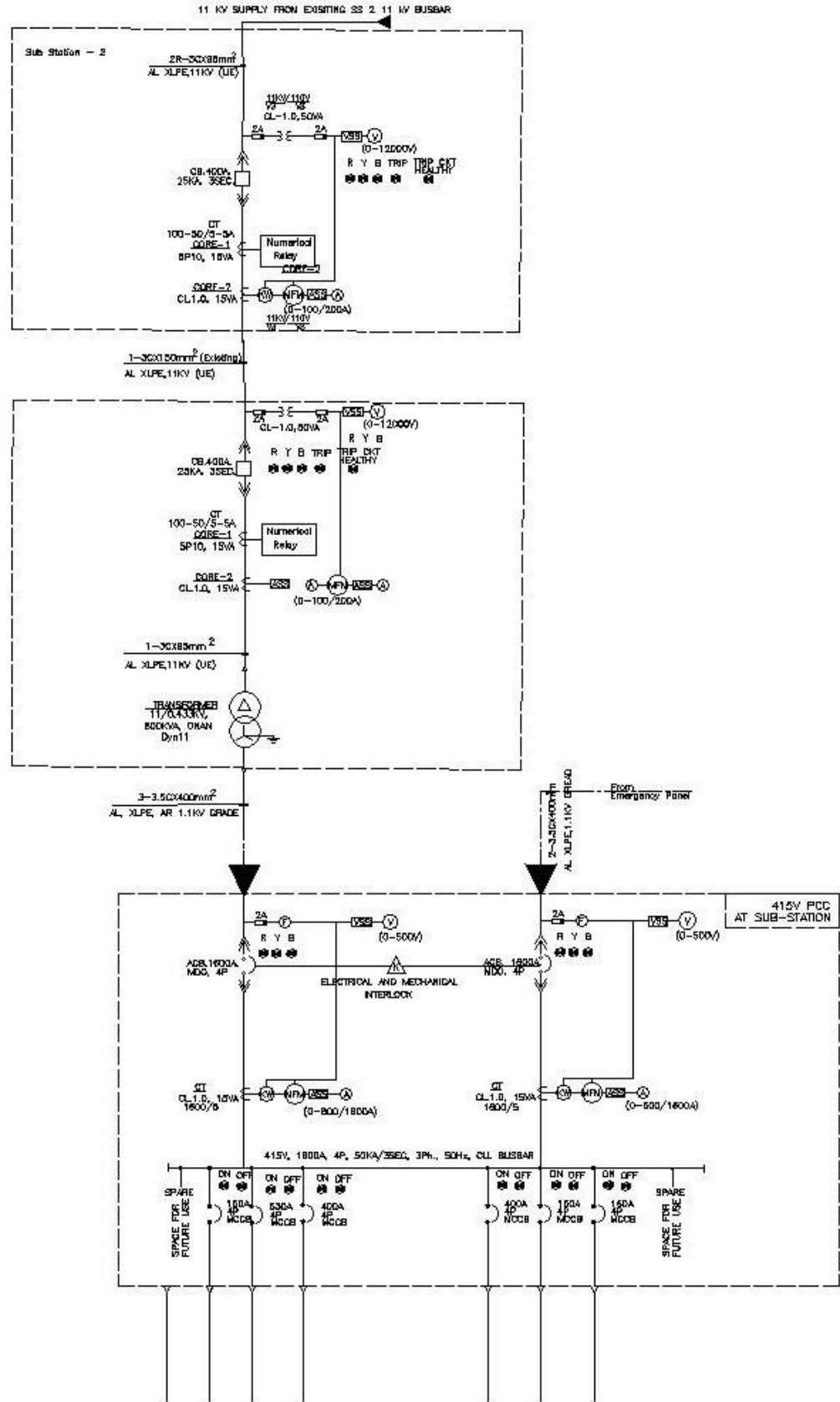

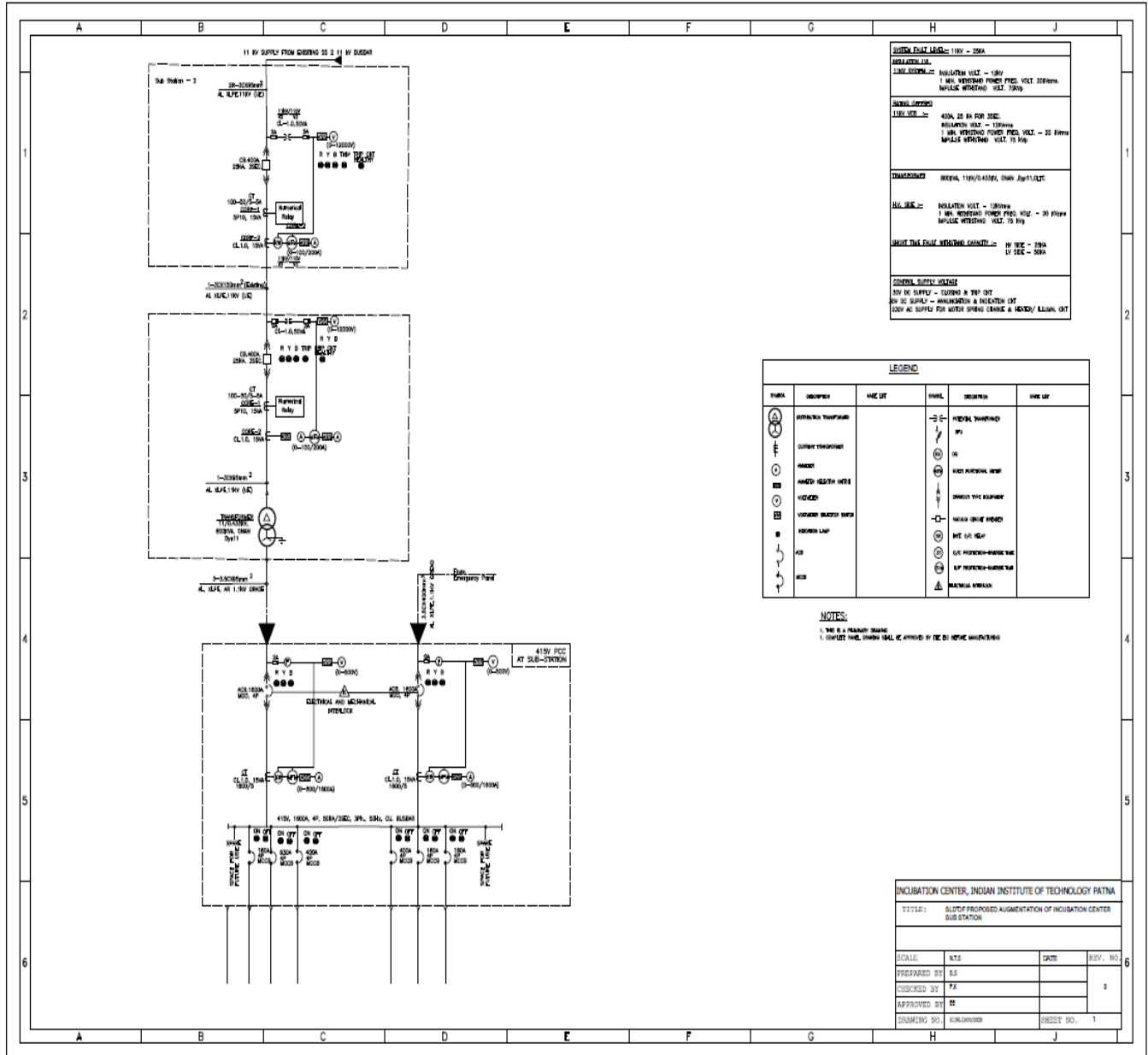

10. LIST OF APPROVED MAKES.

1.	Transformer	<ul style="list-style-type: none"> • Crompton Greaves • Voltamp • Schnieder • ABB
2.	HT/LT Power Cable	<ul style="list-style-type: none"> • Havells • Polycab • KEI • RR Kable
3.	Cable Gland , Lug	<ul style="list-style-type: none"> • Commet • Dowells • Raychem • Gripwell
4.	HT Panel	<ul style="list-style-type: none"> • Schnieder • ABB • Siemens
5.	VCB	<ul style="list-style-type: none"> • Schnieder • ABB • Siemens
6.	LT Electrical Panel	<ul style="list-style-type: none"> • CPRI Approved Type tested Electrical Panel Manufacturer as approved by E-in-Charge.
7.	MCCB, MCB	<ul style="list-style-type: none"> • L&T, • Siemens, • Legrand, • ABB
8.	Digital Multifunction Meter, Digital Voltmeter	<ul style="list-style-type: none"> • L&T, • Schneider (Conzerv), • AE
9.	End termination kit	<ul style="list-style-type: none"> • 3M • Raychem • Densons
10.	Changeover panel	<ul style="list-style-type: none"> • L&T, • ABB • Legrand
11.	All other materials	<ul style="list-style-type: none"> • Make and sample to be approved by Engineer in charge before use of work.

Note:- Agency has to submit manufacturer test certificates of major items.

11 - SCHEDULES

SCHEDULE `A`

Schedule of quantities enclosed.

SCHEDULE `B`

Schedule of materials to be issued to the contractor.

- Nil -

SCHEDULE `C`

Tools and plants shall be hired to the contractor by the Institute.

- Nil -

SCHEDULE `D`

Extra schedule for specific requirements/ document for the work, if any.

- Nil -

SCHEDULE `E`

Schedule of components of cement, steel & other materials Labour etc. for price escalation.

- Nil -

SCHEDULE `F`

Refer to Conditions and Clauses of document.

Definitions :		
i)	HOD IWD	Head In charge.
ii)	Department	Institute Works Department
iii)	Engineer-in-Charge	EE(Electrical)
iv)	Tender Accepting Authority	Registrar, Indian Institute of Technology Patna

v)	COPH	15 %
vi)	Standard Schedule of Rates	(i). C.P.W.D. Delhi Schedule of Rates 2016 with up to date correction slips issued up to the date of receipt of tenders.
(vii)	Time allowed for submission of performance guarantee from the date of issue of letter of acceptance.	N. A.
(viii)	Authority to give fair & reasonable extension of time for completion of work.	Director, IIT Patna

12- Payment Terms

1. 50% of item cost after successful supply at site.
2. 25% of item cost after successful installation.
3. 20% of item cost after successful testing and commissioning.
4. 5% security deposit after successful 1year of DLP Period.

13- SPECIAL TERMS & CONDITIONS

1. Rates quoted in the financial bid must be inclusive of all central, state, local taxes, insurances, levy, cess, transportation & accommodation charge etc. including trade tax on works contract and GST applicable. There should be no increase or variation in the tendered price even in case of changes in GST/service tax, etc. Rate are also inclusive of payment to the Labour Department in accordance with the prevailing Labour law, including all statutory liability fixed by the Labour commissioner or any other law enforcement agency.
2. Agency shall be solely responsible for payment of wages/salaries and allowances to their personnel as per the rules or act applicable under government order. All central, state, local laws & bye laws applicable will be obeyed by the agency.
3. Without taking prior approval from the IITP Engineer-in -charge, no fittings/materials will be removed for the purpose of repairs/replacement.
4. The agency shall further keep the IITP Engineer-in-charge indemnified against any loss to the IITP property and assets. The IITP shall have further right to adjust and/or deduct any of the amounts as aforesaid from the payments due to the agency under this contract.
5. The agency shall ensure that the persons so deployed do not allow any property of the IITP related to Equipment's to be taken out of the premises without a Gate Pass signed by the designated officials of the IITP.

6. The agency shall at his own cost, if required, take necessary insurance cover in respect of the aforesaid services rendered to IIT Patna and The agency shall comply with the statutory provisions of Contract Labor (Regulation & Abolition) Act, 1970; Employees State Insurance Act; Workman's Compensation Act, 1923; Payment of Wages Act, 1936; The Employees Provident Fund (and Miscellaneous Provisions) Act, 1952; Payment of Bonus Act, 1965; The Minimum Wages Act, 1948; Employer's Liability Act, 1938; and/or any other rules/regulations and/or statutes that may be applicable to them. The agency shall indemnify the Institute against all claims which may be made upon the Institute whether under the aforesaid statutes or any other statute in force during the currency of this contract.
7. In the event of the agency committing a default or breach of any of the provisions of the Labour Laws including the provisions of Contract Labour (Regulation and Abolition) Act, 1970 as amended from time to time or in furnishing any information, or submitting or filling any statement under the provisions of the said regulations and rules which is materially incorrect, he shall without prejudice to any other liability pay to the IIT Patna, a sum as may be claimed by IIT Patna.
8. Agency shall keep the IIT Patna indemnified against all claims whatsoever in respect of the employees deployed by the agency, in case any employee of the agency so deployed enters in dispute of any nature whatsoever, it will be the primary responsibility of the agency to contest the same. In case IIT Patna is made party and is supposed to contest the case, the IIT Patna will be reimbursed for the actual expenses incurred towards Counsel fee and other expenses, which shall be paid in advance by the agency to IIT Patna on demand. Further, the agency shall ensure that no financial or any other liability comes on IIT Patna in this respect of any nature whatsoever and shall keep IIT Patna indemnified in this respect.
9. No accommodation facility will be provided by the IIT Patna.
10. Income tax/ other applicable taxes if any will be deducted at source as per the rules in force from the bill and the amount so deducted will be credited to the Income tax/concerned authority and a certificate of the amount credit will be issued by the Account Section of Institute.
11. Institute reserve the right to curtail or enhance the scope of work either by deletion of certain items entirely or by reducing/increasing the quantities of certain items as required and reviewed by the Institute from time to time and therefore, the final value of the work shall be worked out and paid to the extent of work actually carried out.
12. In the event of any question, dispute/difference arising under the agreement or in connection herewith (except as to matters the decision of which is specially provided under the agreement) the same shall be referred to the sole arbitration by the Director, IIT Patna & his decision will be final and binding.
13. IIT Patna shall not be responsible for any expense incurred by bidders in connection with the preparation & submission of their bids, site visit and other expenses incurred during bidding process.
14. The Arbitrator may give interim awards and/or directions, as may be required, Subject to the aforesaid provisions the Arbitrator & Conciliation Act, 1996 and the rules made hereunder and any modification thereof from time to time being in force shall be deemed to apply to the arbitration proceedings under this clause.

15. Bidder should not be under liquidation, court receivership or similar proceeding and shall submit certificate for the same.

16. Force Majeure:-

- a) Notwithstanding the provisions stated above, failure to provide the services by agency shall not be liable for forfeiture of its security or penalty & not be constructed as breach of contract at an event of force majeure.
- b) For purposes of this clause, "Force Majeure" means an event beyond the control of the agency and not involving the agency/service provider's fault or negligence and not foreseeable. Such events may include, but are not limited to, acts of the service provider either in its sovereign or contractual capacity, wars or revolutions fires, floods.
- c) If a Force Majeure situation arises, the agency/ service provider shall promptly notify the Engineer In-Charge in writing of such conditions and the cause thereof. Unless otherwise directed by the employer in writing, the service provider shall continue to perform its obligations under the contract as far as is reasonably practical, and shall seek all reasonable alternative means for performance not prevented by the force majeure event.

17. **Theft of Parts:** - Agency shall be fully responsible for theft, burglary, fire or any mischievous deeds by his workers/staff and shall replace the items under such category. Any loss occurred due to negligence will be recovered from the agency.

18. **JURISDICTION:** Disputes of any nature that may be arise in connection with the execution of this order shall be governed by the laws of India and subject to the jurisdiction of courts situated in Patna, India only.

ANNEXURE - I

IDMENNITY BOND

(On Non- Judicial Stamp Paper of Rs. 100/-)

Know all men by these presents that I/We do hereby execute Indemnity Bond in favor of the IITP on this _____ day of _____ 2024.

WHEREAS, IIT Patna, Registrar has appointed _____ as the contractors for proposed work at IIT Patna.

THIS DEED WITNESS AS FOLLOWS:

I/We hereby do Indemnify and save harmless IIT Patna, Registrar against any third party claims, civil or criminal complaints/liabilities, site mishaps and other accidents or disputes and/or damages occurring or arising out of any mishaps at the site due to faulty work, negligence, faulty construction and/or for violating any law, rules and regulations in force, for the time being while executing /executed works by me/us.

Any damages and loss or expense due to or resulting from any negligence or breach of duty on the part of me/us or my sub contractors if any, servants or agents.

Any claim by an employee of mine/ours or of sub contractors if any, under the workmen's Compensation Act and Owners liability Act 1939 or any other law, rules and regulations in force for the time being and any acts replacing and/or amending the same or any of the same as may be in force at the time and under any law in respect of injuries to persons or property arising out of land and in the course of execution of the contract work and/or arising out of and in the course of employment of any workman/employee.

Any act or omission of mine/ours of sub-contractors if any, our/their servants or agents which may involve any loss, damage, liability, civil or criminal action.

NAME AND ADDRESS

Contractor

IN WITNESS WHEREOF THE
_____ of _____ 2024.

SIGNED AND DELIVERED BY THE

AFORESAID _____

IN THE PRESENCE OF WITNESSES:

1.

2.

ANNEXURE - 2

**PROFORMA FOR PERFORMANCE
BANK GUARANTEE**
(TO BE STAMPED IN ACCORDANCE WITH STAMP ACT, IF ANY, OF THE COUNTRY OF THE
ISSUING BANK)

Ref.

Bank Guarantee No,

Date

Indian Institute of Technology Patna

Amhara, Bihta- 801103

Dear Sirs,

We refer to the contract No. _____ signed on

_____ [dated] ("the Contract") between you and
_____ ("the contractoe")

_____ concerning

(Brief description of the scope of work).

By this Bank Guarantee, we, the undersigned,

_____ a Bank (or company) organized under the law of

_____ and having its Branch office at

_____ and registered /

principal office at _____ do hereby irrevocably guarantee

payment to you up to five (5%) of the Contract price until Three (3) months days beyond the Defect Liability period.

We undertake to make payment under this Bank Guarantee upon receipt by us of your first written demand signed by your duly authorized officer declaring the Contractor to be in default under the Contract and without cavil or argument any sum or sums within the above named limits, without your need to prove or show grounds or reasons for your demand and without the right of the Contractor to dispute or question such demand. our liability under this Bank Guarantee shall be to pay you the sum so requested or the amount then guaranteed

hereunder whichever is less in respect of any demand duly made hereunder prior to expiry of the Bank Guarantee, without being entitled to inquire whether or not this payment is lawfully demanded.

This Bank Guarantee shall be valid from the date of issue until 3 months beyond the Defect Liability Period of the Facilities i.e. upto an inclusive of

_____ (year, month and date).

Except for the documents herein specified, no other documents or other action shall be required, notwithstanding any applicable law or regulation.

If the Defect Liability Period is extended with respect to the Facilities in accordance with the Contract, the validity of this Bank Guarantee shall be extended with respect to five percent (5%) of the Contract Price of that part until expiry of 3 months beyond such extended Defect Liability Period.

Our liability under this Bank Guarantee shall become null and void immediately upon its expiry, whether it is returned or not, and no claim may be made hereunder within one month from the date of such expiry or after the aggregate of the sums paid by us to you shall equal the sums guaranteed hereunder, whichever is the earlier.

All notices to be given under shall be given by registered (airmail) posts to the addressee at the address herein set out or as otherwise advised by and between the parties hereto.

We hereby agree that any part of the Contract may be amended, renewed, extended, modified, compromised, released or discharged by mutual agreement between you and the Contractor, and this security may be exchanged or surrendered without in any way impairing or affecting our liabilities hereunder without notices to us and without the necessity for any additional endorsement, consent or guarantee by us, provided, however, that the sum guaranteed shall not be increased or decreased. No action, event or condition which by any applicable law should operate to discharge us from liability hereunder shall have any effect and we hereby waive any right we may have to apply such law so that in all respects our liability hereunder shall be irrevocable and, except as stated herein, unconditional in all respects.

Yours truly,

Name of the Bank

Authorized Signature

Signature of

Witness.Name :

.Address .

Note:

1. The non-judicial stamp papers of appropriate value shall be purchased in the name of the Bank who issues the 'Bank Guarantee'.
2. Performance Security is to be provided by the successful bidder in the form of a Bank Guarantee which should be issued either:
 - (a) by a reputed bank located in the country of Employer and acceptable to the Employer, or
 - (b) by a foreign bank confirmed by either its correspondent bank located in the country of Employer which should be reputed and acceptable to the Employer, or
 - (c) by a Public Sector Bank in the country of Employer.

All banks except Public Sector Banks of the Employer's country shall have with overall international corporate rating or rating of long term debt not less than A- (A minus) or equivalent by a reputed rating agency.

ANNEXURE - 3

TENDER ACCEPTANCE LETTER

(On Company / firm's Letterhead)

To,
The Registrar
I.I.T. Patna,
Bihta, Patna – 801106.

Date:

Sir,

Ref: Tender No. IITP/IWD/IC/Elect./NIT-01/23-24 'Augmentation of the Electrical installation by SITC of Transformer , HT/LT Panels and allied works at Incubation Centre, IIT Patna'

I/we have carefully gone through the Terms & Conditions as mentioned in the above referred Tender document as per your advertisement, given in the abovementioned website(s).

1. I/we declare that all the provisions of this Tender are unconditionally acceptable to my company. I /we further certify that I'm an authorized signatory of my company and am, therefore, competent to make this declaration.
2. I/we hereby certify that I/we have read the entire terms and conditions of the tender documents from Page No. ...to... (including all documents like annexure(s), schedules(s), etc..) which form part of the contract agreement and I/we shall abide hereby by the terms / conditions /clauses contained therein.
3. The corrigendum(s) issued from time to time by your department /organizations too have also been taken into consideration, while submitting this acceptance letter.
4. I/we certify that all information furnished by the our Firm is true and correct and if at any stage, it has been found that the agency has furnished any wrong declaration / forged documents, the Competent Authority of IIT Patna may terminate contract with immediate effect without assigning any reason there of and suitable legal action should be taken against the agency which may include blacklisting / debarment from participating in any tender of IIT Patna for the period, approved by the competent authority.

Yours faithfully,

(Signature of the Bidder, with Official Seal)

ANNEXURE - 4

DECLARATION OF ANNUAL TURNOVER (Balance Sheet)

(On Company / firm's Letterhead)

Date:

To,
The Registrar
I.I.T. Patna,
Bihta, Patna – 801106.

Sir,

Ref: Tender No. IITP/IWD/IC/Elect./NIT-01/23-24 for 'Augmentation of the Electrical installation by SITC of Transformer , HT/LT Panels and allied works at Incubation Centre, IIT Patna'

1) I/we hereby declare that, our firm's Annual Turnover as follows, and I/we have also supported an Audited Accounts for your references:

F. Y. 2020 – 21	
F. Y. 2021 – 22	
F. Y. 2022 – 23	

Yours faithfully,

(Signature of the Bidder, with Official Seal)

ANNEXURE - 5

DETAILS OF THE FIRM

Ref: Tender No. IITP/IWD/IC/Elect./NIT- 01 /23-24 for 'Augmentation of the Electrical installation by SITC of Transformer , HT/LT Panels and allied works at Incubation Centre, IIT Patna'

1.	Name of Firm	
2.	Registered/Postal Address	
3.	Office Address in Patna (if any)	
4.	Working Email id	
5.	Telephone no/Fax no/Mobile	
6.	Particulars of Registration with various government bodies/organization.	
7.	Details of Similar nature projects completed during past seven years.(Attach separate sheet if needed)	
8.	Were you ever debarred/ blacklisted by any department during the past three years?	
9.	Name of Directors /Partners with Address	
10.	Permanent Account Number (PAN) No	
11.	GST Registration No	
12.	BANK DETAILS:	
a.	Bank Name	
b.	Branch Address	
c.	Account No	
d.	Type of Account (Current/Savings)	
e.	MICR No.	
f.	IFSC Code	

Date: Name of the Authorized Signatory

Place: Stamp & Signature

Special condition for Safety at the Work Site

The contractor will identify one of the supervisors for taking care of implementation of Safety systems.

The Contractor should follow the following General Guidelines governing the safety rules as laid down under:

1. Nobody is allowed to work without wearing safety helmet. Chinstrap of safety helmet shall be always on. Drivers, helpers and operators are no exception.
2. No one is allowed to work at or more than three meters height without wearing safety belt and anchoring the lanyard of safety belt to firm support preferably at shoulder level.
3. No one is allowed to work without adequate foot protection.
4. Usage of eye protection equipment shall be ensured when workmen are engaged for grinding, chipping, welding and gas-cutting. For other jobs as and when site safety co-ordinator insists eye protection has to be provided.
5. All safety appliances like Safety shoes, Safety gloves, Safety helmet, Safety belt, Safety goggles etc. shall be arranged before starting the job.
6. All excavated pits shall be barricaded & barricading to be maintained till the backfilling is done. Safe approach to be ensured into every excavation.
7. Adequate illumination at workplace shall be ensured before starting the job at night.
8. All the dangerous moving parts of the portable / fixed machinery being used shall be adequately guarded.
9. Ladders being used at site shall be adequately secured at bottom and top. Ladders shall not be used as work platforms.
10. Material shall not be thrown from the height. If required, the area shall be barricaded and one person shall be posted outside the barricading for preventing the tre-passers from entering the area.
11. Other than electricians no one is allowed to carry out electrical connections, repairs on electrical equipment or other jobs related thereto.
12. All electrical connections shall be made using 3 or 5 core cables, having a earth wire.
13. Inserting of bare wires for tapping the power from electrical sockets is completely prohibited.
14. A tools and tackles inspection register must be maintained and updated regularly.
15. Debris, scrap and other materials to be cleared from time to time from the workplace and at the time of closing of work every day.
16. All the unsafe conditions, unsafe acts identified by contractors, reported by site supervisors and / or safety personnel to be corrected on priority basis.
17. No children shall be allowed to enter the workplace.

18. All the lifting tools and tackles shall be stored properly when not in use.
19. Clamps shall be used on Return cables to ensure proper earthing for welding works.
20. Return cables shall be used for earthing.
21. All the pressure gauges used in gas cutting apparatus shall be in good working condition.
22. Proper eye washing facilities shall be made in areas where chemicals are handled.
23. Connectors and hose clamps are used for making welding hose connections.
24. All underground cables for supplying construction power shall be routed using conduit pipes.
25. Spill trays shall be used to contain the oil spills while transferring / storing them.
26. Tapping of power by cutting electric cables in between must be avoided. Proper junction boxes must be used.

Registrar
IIT Patna